



# KAC20~50DP2 Series Commercial and Industrial Power Conversion System

User Manual



2025-12-V1.0 AU



# Table of Contents

1 About This Manual .....	3
1.1 Introduction .....	3
1.2 Applicable products .....	3
1.3 Product model naming rules .....	3
1.4 Manual description .....	3
1.5 Sign description.....	2
2 Safety Instructions .....	3
2.1 Personnel requirements.....	3
2.2 Safety warning operation .....	3
2.3 Body identification protection .....	3
2.4 Electricity safety precautions .....	4
2.5 Environmental space requirements .....	5
2.6 Live test specification .....	5
2.7 Parameter setting .....	6
2.8 Maintenance or repair specifications .....	6
2.9 Product scrapping.....	6
2.10 Other precautions .....	6
3 Product Introduction .....	8
3.1 Power Conversion System.....	8
3.2 Product appearance .....	9
3.3 Main power topology .....	10
3.4 Product characteristics.....	10
3.5 Communication scheme .....	11
4 Converter mode and function .....	12
4.1 Mode introduction .....	12
4.2 Functions of Power Conversion System .....	12
4.3 Introduction to converter status .....	13
5 Installation.....	14
5.1 Precautions before installation.....	14
5.2 Installation process.....	17
5.3 Installation preparation.....	19
5.4 Machine transportation .....	22
5.5 Positioning and fixing .....	23
5.6 Installation of Power Conversion System in the battery cabinet .....	24

5.7 Air duct design and installation .....	26
6 Electrical Installation Guidance .....	27
6.1 Cable requirements .....	27
6.2 Wiring specifications.....	28
6.3 Fixation and protection of connecting cables .....	28
6.4 Opening terminal box .....	31
6.5 DC side wiring .....	31
6.6 AC side wiring .....	35
6.7 Communication interface.....	39
6.8 System grounding.....	41
6.9 Installation completion .....	41
7 Commissioning Operation.....	42
7.1 Inspection before startup .....	42
7.2 Basic Setting.....	43
7.3 Startup and shutdown operation process .....	53
7.4 Fault shutdown operation process .....	53
8 Maintenance and Troubleshooting .....	54
8.1 Description .....	54
8.2 Precautions .....	54
8.3 Troubleshooting .....	56
Appendix I: Technical Parameters .....	60
Appendix II: Explanation of Terms .....	62

# 1 About This Manual

## 1.1 Introduction

Dear customers, thank you very much for using the Power Conversion System developed and produced by Shenzhen Kstar New Energy Co., Ltd. We sincerely hope that this product meets your requirements and invite you to provide valuable feedback regarding its performance and functionality. Your insights are crucial to our ongoing efforts to enhance the product.

## 1.2 Applicable products

This manual is applicable to the industrial and commercial Power Conversion System KAC50DP2 of Shenzhen Kstar New Energy Co., Ltd.

※In this manual, unless otherwise specified, all references to "converter" and "Power Conversion System" refer to this series of products.

## 1.3 Product model naming rules

K	A	C	50	D	P	2
Field 1	Field 2	Field 3	Field 4	Field 5	Field 6	Field 7

Field 1	Field 2	Field 3	Field 4	Field 5	Field 6	Field 7
K	A	C	50	D	P	2
KSTAR	AC	Converter	Power	Outdoor	Represents PV	Generation 2

## 1.4 Manual description

- This manual is the dedicated instruction for the KAC20-50DP2 provided to users by Shenzhen Kstar New Energy Co., Ltd. **The following uses KAC50DP2 to refer to KAC20-50DP2 series.**

This manual describes product-related information, installation instructions, operation, maintenance and troubleshooting in detail. Before proceeding with the installation and commissioning operation of the equipment, the user must read and understand all instructions contained in this manual and be familiar with the relevant safety symbols.

- The reader should have a certain degree of electrical theory, electrical wiring and professional mechanical knowledge. Please read this manual carefully before installing this product and ensure that it is easily accessible to relevant personnel.

The contents, pictures, logos, symbols, etc. used in this manual are all owned by Shenzhen Kstar New Energy Co., Ltd. Non-personnel of the Company shall not publicly reprint all or part of the contents without written authorization.

## 1.5 Sign description

In order to ensure the personal and property safety of users when using this product and to better use of this product, the manual provides relevant information and highlights it with appropriate symbols.

The symbols that may be used in this manual are listed below. Please read them carefully.

### **Danger**

Indicates a high potential hazard, which will result in death or serious injury if not avoided.

### **Warning**

Indicates a moderate potential hazard, which may result in death or serious injury if not avoided.

### **Caution**



Indicates a low potential hazard, which may result in moderate or minor injury if not avoided.

### **Attention**

Indicates a potential risk, which may result in equipment malfunction or failure alarm if not avoided.

"s" emphasize and supplement the content and may also provide tips for optimizing the use of the product.

Please always pay attention to the danger and warning signs on the body, including:

Identifier	Identification description
	This sign indicates that there is high voltage inside the body, and touching it may cause electric shock hazard.
	This symbol indicates that the temperature here is higher than the acceptable range of human body. Do not touch it arbitrarily to avoid personal injury.
	This symbol indicates that this is the protective earthing (PE) end, which needs to be firmly grounded to ensure the safety of operators.

## 2 Safety Instructions

### 2.1 Personnel requirements

- Only professional electricians or personnel with professional qualifications can be allowed to operate this product.
- The operator shall be fully familiar with the structure and working principle of the entire energy storage system.
- The operator shall be fully familiar with this manual *User Manual of KAC20-50DP2 Power Conversion System*
- The operator shall be fully familiar with the relevant standards of the country/region where the project is located.

#### Warning

- It is strictly forbidden to perform maintenance or repair operations when the equipment is energized!
- When maintaining or repairing the equipment, **at least two persons** must be on site. The equipment has been safely disconnected and a 10-minute wait is required for the converter to discharge completely before performing maintenance or repair operations.

### 2.2 Safety warning operation

When performing installation, routine maintenance, inspection, and other operations on the Power Conversion System, measures should be taken to prevent unrelated personnel from approaching and causing misoperation or accidents. Observe the followings:

- Set up clear signage at the front and rear stage switches of the Power Conversion System to prevent accidental switch closure.
- Set up warning signs or safety warning tapes near the operation area.
- After maintenance or repair operations are completed, be sure to lock the upper cover tightly.

### 2.3 Body identification protection

- The warning sign on the Power Conversion System body contains important information for the safe operation of the Power Conversion System. It is strictly prohibited to tear or damage it intentionally!
- The nameplate is installed on the inside of the front door of the Power Conversion System, and the nameplate contains important parameter information related to the product. It is strictly prohibited to tear or damage it intentionally!
- Once the body identification is damaged or blurred, please be sure to contact Shenzhen Kstar New Energy Co., Ltd.

#### Attention

- Please ensure that the body identification is clear and readable at all times.
- Once the body identification is damaged or blurred, be sure to replace it immediately.

## 2.4 Electricity safety precautions

### 2.4.1 Electrical safety

#### Danger

Make sure that the equipment is properly grounded before use!

The enclosure may have a large leakage current to the human body, so please do not touch it when the machine is working.

#### Danger

##### **There is fatal high voltage inside the product!**

- Do not touch the terminals or conductors connected to the grid circuit.
- Pay attention to all instructions or safety instructions on connection to the grid, and observe the warning signs on the product.
- Observe the safety precautions listed in this manual and other documents related to this equipment.

#### Danger

##### **Damaged equipment or system malfunctions may cause electric shock!**

- Before operation, visually inspect the equipment for any damage or other hazards.
- Check whether other external equipment or circuit connections are safe.
- Confirm that the equipment is in a safe state before operation.

#### Warning

The grounding conductor must not be damaged, and the product must not be operated before the grounding conductor is installed, otherwise it may cause personal injury or product damage.

Please select the measurement equipment with a suitable range. Overvoltage may cause damage to the measurement equipment and personal injury!

#### Warning

The external protective earthing terminal must meet at least one of the following requirements:

- When the cross-sectional area of the grounding cable is greater than or equal to 10mm<sup>2</sup> (copper wire) or 16mm<sup>2</sup> (aluminum wire), it is recommended that both the external protective earthing terminal and the AC side grounding terminal be grounded.
- When the cross-sectional area of the grounding cable is less than 10mm<sup>2</sup> (copper wire) or 16mm<sup>2</sup> (aluminum wire), please ensure that both the external protective earthing terminal and the AC side grounding terminal are grounded.

If other methods of grounding can meet local standards and relevant safety regulations, the grounding connection can be carried out in accordance with local standards and regulations, and the Company will not assume any responsibility for the possible consequences.

**EARTH FUALT INTRODUCTION**

Earth faults caused by insulation failure or accidental contact between live parts and ground that creates a low-resistance path for current to flow to earth, represent significant risks that require proper understanding and protective measures to mitigate their potentially dangerous effects.

**EARTH FUALT ALARM**

In the event of an earth fault, the inverter will display a fault code and push an alarm notification via the KSTAR EMS.

## 2.4.2 Electrostatic safety

**⚠ Attention**

Electrostatic sensitive components on the circuit board or other places may be damaged due to improper operation or contact by operators.

- The operator is requested to avoid unnecessary contact with the circuit board.
- The operator is requested to comply with electrostatic protection standards, such as wearing anti-static wristbands.

## 2.5 Environmental space requirements

### 2.5.1 Escape route requirements

To ensure that workers can quickly evacuate the site in the event of an accident, please observe the following:

- Do not place flammable or explosive items around the converter.
- It is strictly forbidden to pile up debris in the escape route or occupy the escape route in any form.

### 2.5.2 Moisture protection

Do not open the hood in high humidity or rainy days!

## 2.6 Live test specification

### 2.6.1 Live measurement

**⚠ Danger**

There is a high voltage in the equipment, and accidental contact may cause fatal electric shock. Therefore, during live measurement, you should:

- Take protective measures (such as wearing insulating gloves, insulating shoes, etc.).
- **At least two persons must be present on site to ensure personal safety.**

## 2.6.2 Measurement equipment usage

When performing electrical connections, commissioning operations, and other operations on the Power Conversion System, it is necessary to use relevant electrical measurement equipment to ensure that the electrical parameters meet the requirements.

### Warning

- Select high-quality measurement equipment with a range and usable conditions that meet on-site requirements.
- Ensure the connection and use of the measurement equipment are correct and standardized to prevent hazards such as electric arcs.

## 2.7 Parameter setting

The parameters are closely related to the operation of the Power Conversion System. These parameters can only be modified and set after reliability analysis and evaluation of the operating conditions of the system and the Power Conversion System, and the specific parameters are set in the background (upper computer or EMS).

### Warning

- Improper parameter setting may affect the normal function of the Power Conversion System!
- Only authorized professionals can set the parameters of the Power Conversion System.

## 2.8 Maintenance or repair specifications

Pay attention to the following points when performing maintenance or repair operations on the equipment:

- Ensure that the Power Conversion System will not be accidentally re-energized.
- Use a multimeter to ensure that the internal discharge of the Power Conversion System is completed.
- Ensure that the equipment is well grounded.
- Live parts must be insulated and covered with insulating materials.
- After the Power Conversion System is shut down and the AC/DC power supply is disconnected, the upper cover can be opened for maintenance or repair of the Power Conversion System for at least 10 minutes.
- It is necessary to ensure that the escape route is completely unobstructed throughout the maintenance and repair process.

## 2.9 Product scrapping

- When the Power Conversion System needs to be discarded, it cannot be disposed of as a conventional waste product.
- Please contact a local authorized professional recycling agency.

## 2.10 Other precautions

The following protective or emergency measures shall be taken according to the needs of the site:

- When performing various operations such as maintenance and repair of the equipment, relevant personnel shall take appropriate protective measures as required, such as wearing noise-proof earplugs, insulating shoes, and anti-scald

gloves.

- The installation site of the Power Conversion System is usually far away from the urban area. Corresponding emergency rescue facilities shall be prepared as required for implementation when necessary.
- Take all necessary auxiliary measures to ensure the safety of personnel and equipment.

 **Attention**

All operations on the Power Conversion System must comply with the relevant standards of the country/region.

 All descriptions in this manual are based on the Power Conversion System with standard configuration. If you have special requirements, please be sure to inform the staff of Shenzhen Kstar New Energy Co., Ltd. when placing an order. For details, please refer to the actual product you received. This manual cannot cover all possible situations during operation, maintenance, repair, etc. If you encounter any situations that are not explained in the manual, please contact Shenzhen Kstar New Energy Co., Ltd. in a timely manner.

## 3 Product Introduction

### 3.1 Power Conversion System

The Power Conversion System (PCS) can efficiently integrate PV renewable energy power generation with the grid on the power generation side. In response to the grid on the AC side, it can realize frequency modulation, peak shaving and valley filling to cooperate with the grid dispatching and stabilize the grid frequency; It can be used on the distribution side to realize peak shaving and valley filling, alleviate the power shortage during the peak period of power consumption, and smooth the waste caused by excess power during the trough of power consumption; It can be used as a large uninterruptible power supply on the power side. It can control the charging and discharging process of the battery, carry out AC/DC conversion, and directly supply power to AC loads without grid. PCS consists of DC/AC bidirectional converter, DC/DC bidirectional converter, MPPT converter, control unit, etc.

The PCS controller receives the background control command through communication, and controls the converter to charge or discharge the battery according to the sign and size of the power command, so as to adjust the active power and reactive power of the grid. The PCS controller communicates with the BMS through the CAN interface to obtain the battery pack status information, which can realize the protective charging and discharging of the battery and ensure the safe operation of the battery.

### 3.2 Product appearance

The appearance and external components of the Power Conversion System are shown in the figure below:

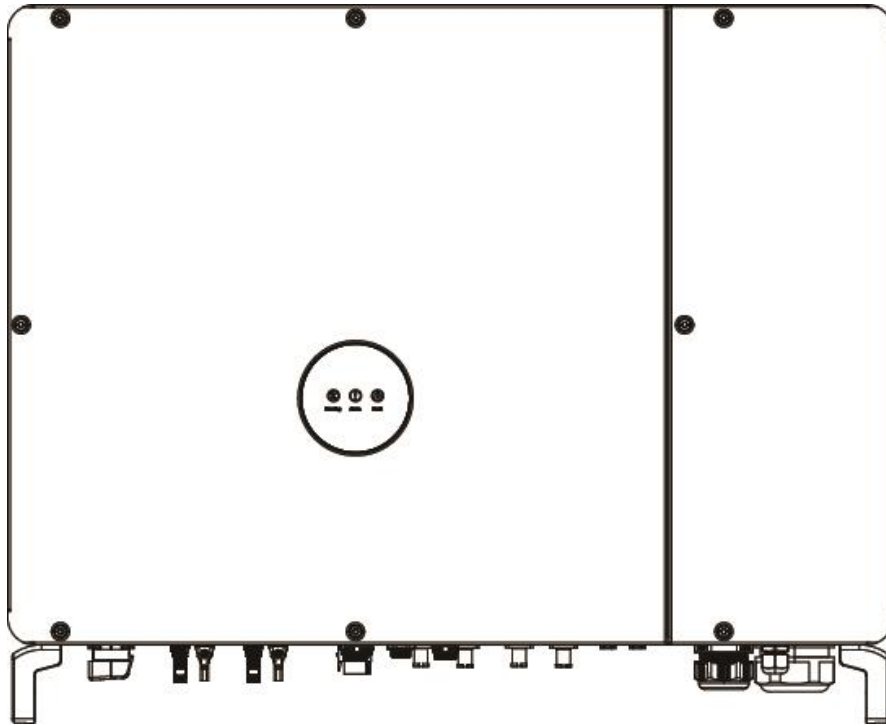

Figure 3-1 Front View of KAC50DP2

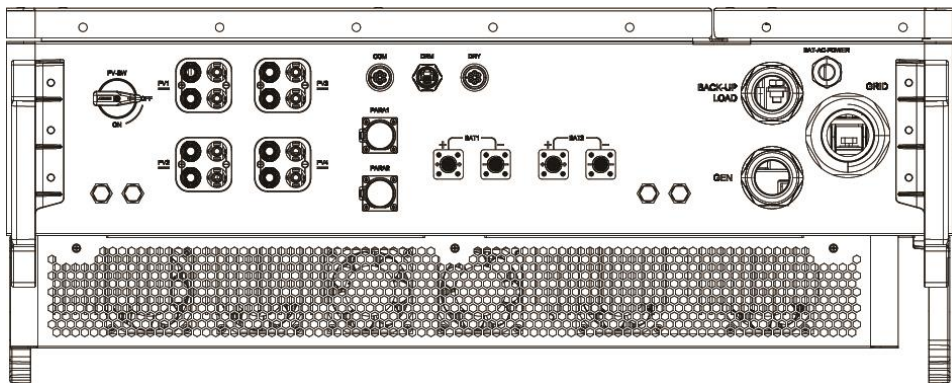

Figure 3-2 Bottom View of KAC50DP2

### 3.3 Main power topology

The converter adopts two-phase staggered BOOST-BUCK+T three-level topology to realize four-quadrant operation; The filter circuit is LCL filter circuit.

The principle of the main circuit inside the Power Conversion System is shown in the figure below:

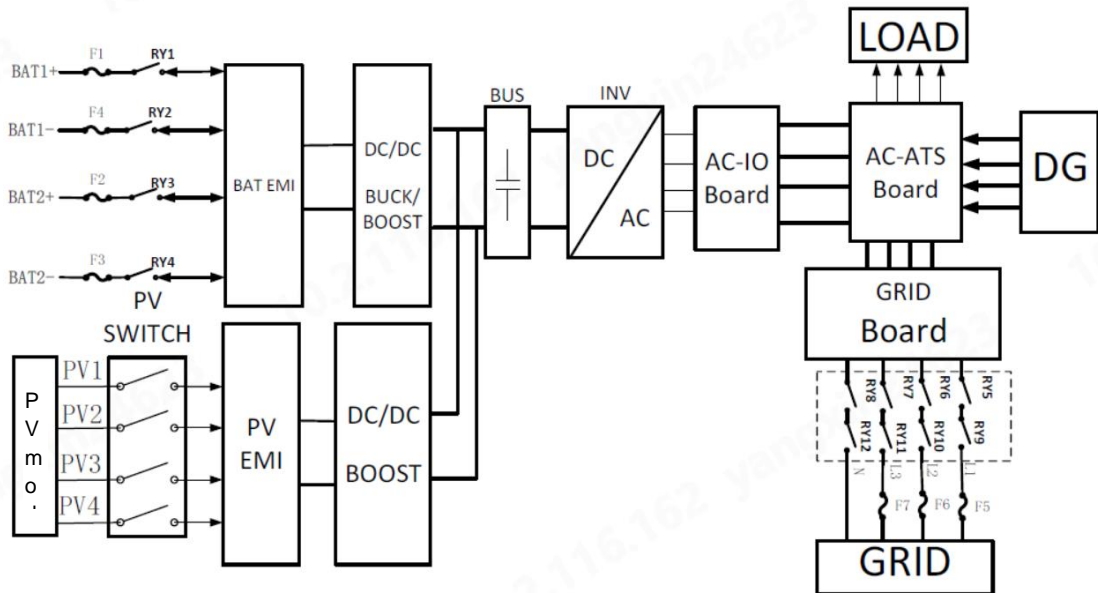

Figure 3-3 Main Circuit Topology of KAC50DP2

### 3.4 Product characteristics

The KAC50DP2 Power Conversion System adopts advanced digital control technology to optimize the control performance and improve the reliability of the system, which is suitable for different battery charging and discharging needs. Its main performance characteristics are as follows:

- It can accept grid dispatching, and the communication methods include CAN, RS485, etc.
- Wide battery input range;
- On-grid mode, off-grid mode, diesel engine mode, hybrid mode and other working modes. Built-in STS on-grid and off-grid switching function;
- It has the functions of independent frequency and voltage regulation and controlled frequency and voltage regulation.
- With off-grid independent inverter function, a microgrid system is established by the Power Conversion System to ensure the power supply of important loads.
- Strong ability to handle unbalanced three-phase loads off-grid. Single phase 100%
- High frequency design scheme with high power density.
- The AC/DC dual auxiliary power supply mode is adopted to improve reliability.
- The internal and external air ducts of the case are designed independently, with excellent heat dissipation.

### 3.5 Communication scheme

#### 3.5.1 Background communication scheme

The Power Conversion System communicates with the EMS via RS485, and the EMS communicates with the upper computer via Ethernet. The Power Conversion System is monitored by the self-designed energy storage system monitoring software.

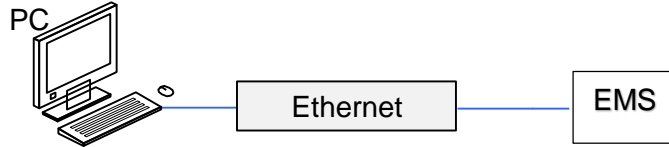

Figure 3-4 Monitoring by PC via Ethernet

#### 3.5.2 EMS communication scheme

The Power Conversion System can communicate with the EMS through the RS485 communication line, and the Power Conversion System can be monitored in real time using the self-designed energy storage system monitoring software.



Figure 3-5 Monitoring by EMS via RS485

#### 3.5.3 BMS communication scheme

Through the CAN communication line, the Power Conversion System can communicate with the BMS to realize data transmission.



Figure 3-6 Data Transmission by BMS via CAN

# 4 Converter mode and function

## 4.1 Mode introduction

### 4.1.1 On-grid mode and off-grid mode

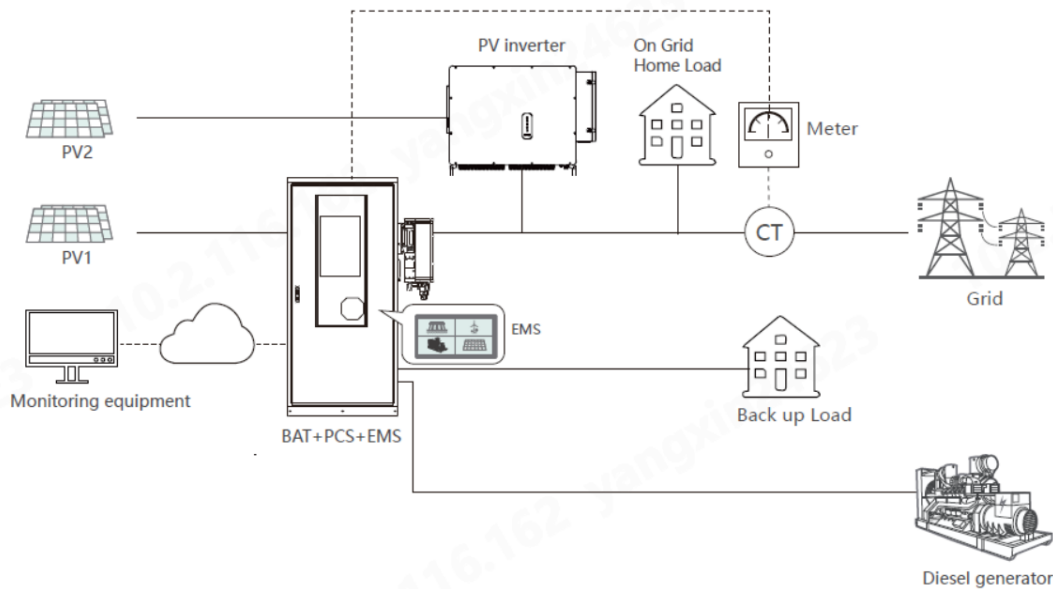

Figure 4-1 System Block Diagram

**On-grid mode:** connected to the public grid, following the grid voltage amplitude/phase and frequency, with island protection.

**Off-grid mode:** In the island state, the PCS works in voltage source mode and outputs a given voltage and frequency.

**Hybrid mode:** When the converter is switched between on-grid mode and off-grid diesel engine mode, it can switch between on-grid mode and off-grid diesel engine mode.

## 4.2 Functions of Power Conversion System

### 4.2.1 Working mode

Input	Output
A) PV	1) Grid, 2) Grid+Battery, 3) Grid+Load, 4) Grid+Battery+Load, 5) Battery+Load
B) PV+Grid	1) Battery, 2) Load, 3) Battery+Load
C) PV+Battery	1) Grid, 2) Load, 3) Grid+Load
D) PV+Grid+Battery	1) Load
E) Grid	1) Battery, 2) Load, 3) Battery+Load
F) Grid + Battery	1) Load
G) Battery	1) Grid, 2) Load, 3) Grid+Load
H) GEN	1) Battery, 2) Load, 3) Battery+Load
I) PV+GEN	1) Battery, 2) Load, 3) Battery+Load

### 4.2.3 Cooling System Startup

The cooling system will start automatically when the Power Conversion System

reaches a certain power or the temperature reaches a threshold, with stepless speed regulation.

### 4.3 Introduction to converter status

The Power Conversion System has 5 states in total, as shown in Table 4-1 below:

Table 4-1 Status and Description

Status	Description	LED status
Self-test	When the DC side switch is turned on, the DC side of the converter will perform self-inspection to check whether the DC side voltage is normal.	Yellow light flashing Red light flashing
Standby	After the self-test is completed, the DC side enters the soft start state. When the soft start is completed, the DC contactor is closed, and the converter is in the standby state.	Yellow light always on Red light always on
On-grid	After the system is in standby state, if the grid side is normal at this time, the user can use EMS or upper computer to set the converter operation mode to on-grid mode. When the converter receives the startup command from EMS or upper computer, the relay on the AC side will be closed, and the system will be in the on-grid mode operation state.	Green light always on
Off-grid	After the system is in standby state, the user can use EMS or upper computer to set the converter operation mode to off-grid mode. When the converter receives the startup command from EMS or upper computer, the relay on the AC side will be closed, and the system will be in off-grid operation state.	Green light always on
Fault	All relays of the Power Conversion System are disconnected, and the system stops working.	Red light always on

#### Warning

When the Power Conversion System fails, it is forbidden to start the equipment again. You can power off and check that there is no problem, and then power on again, otherwise the machine will be damaged.

## 5 Installation

### 5.1 Precautions before installation

- The installation of this series of Power Conversion Systems must be carried out by at least two professionally qualified personnel simultaneously, and all electrical installations must comply with local electrical installation standards. Pay attention to prevent falling and smashing.

#### SAFE HANDLING NOTE

The inverter should be moved by four persons. One inverter weighs approximately 94.5 kg.

Wear protective goggles and a mask to prevent the dust created during drilling from entering the respiratory tract and eyes.

- During installation, do not touch other parts inside the case except for the wiring terminals.
- Safety signs must be set up at all upstream switches that do not switch on during construction.

#### 5.1.1 System Overview

This instruction applies to a system in which two KAC50DP2 hybrid inverters are connected in parallel to a single BC197DE2 battery cabinet. Each inverter provides AC output to the load or grid.

#### 5.1.2 Recommended RCD installation method

To ensure stable operation and safety, an RCD(type A) with 300 mA sensitivity is installed at the combined AC output point of the two KAC50DP2 inverters.

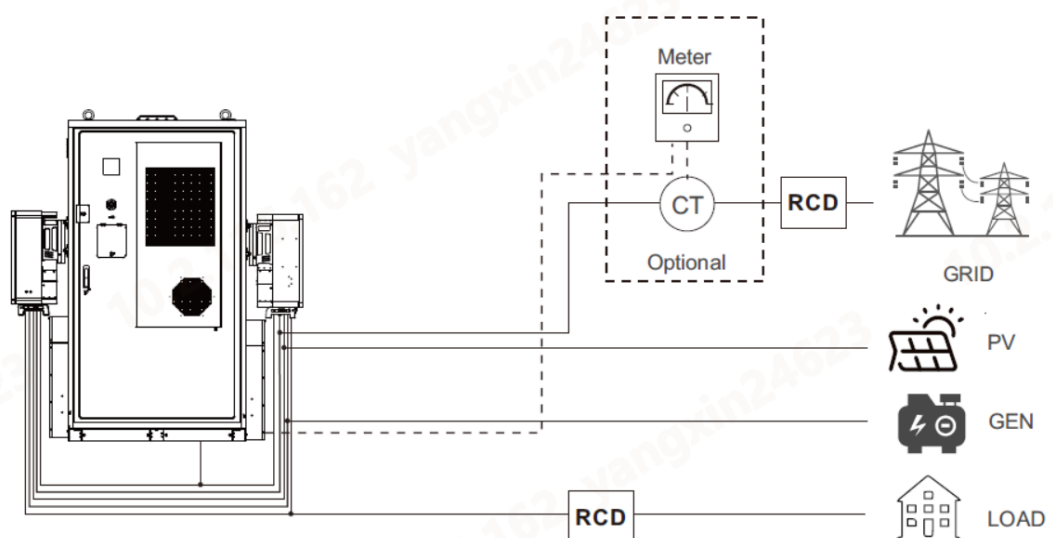

### 5.1.3. Incorrect RCD configuration (to be avoided)

It is not recommended to install 300mA RCD (Residual Current Devices) separately on the AC output of each KAC50DP2 inverter. It may cause false triggering due to the following reasons:

- The inverters share a battery DC power supply. This can lead to circulating leakage currents or a single RCD detecting an unbalanced current back into the circuit, triggering a false alarm.

- The RCD detects the difference between live current and neutral current. Sharing the neutral path when multiple inverters are synchronized and connected to a common load or grid may lead to detection errors, resulting in an unexpected RCD trip.

Wiring method for Australia/New Zealand:

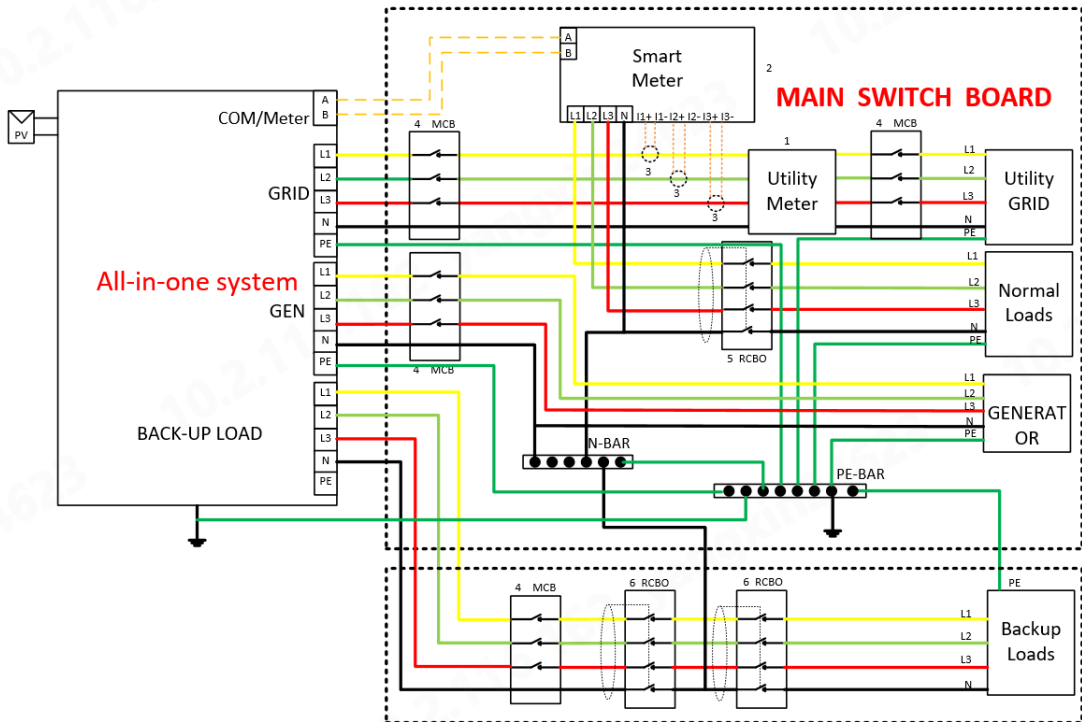

Item	Name	Item	Name
1	Main meter	4	AC circuit breaker(MCB)
2	Smart meter	5	Normal load breaker(RCBO)
3	CT	6	Backup loads breaker(RCBO)

#### **Warning**

This wiring method is for reference only and applicable to the Australia or New Zealand.  
The final installation must comply with local regulations and installation requirements.



Australian/New Zealand DRM wiring method:

The DRM functional test wiring diagram is as follows:

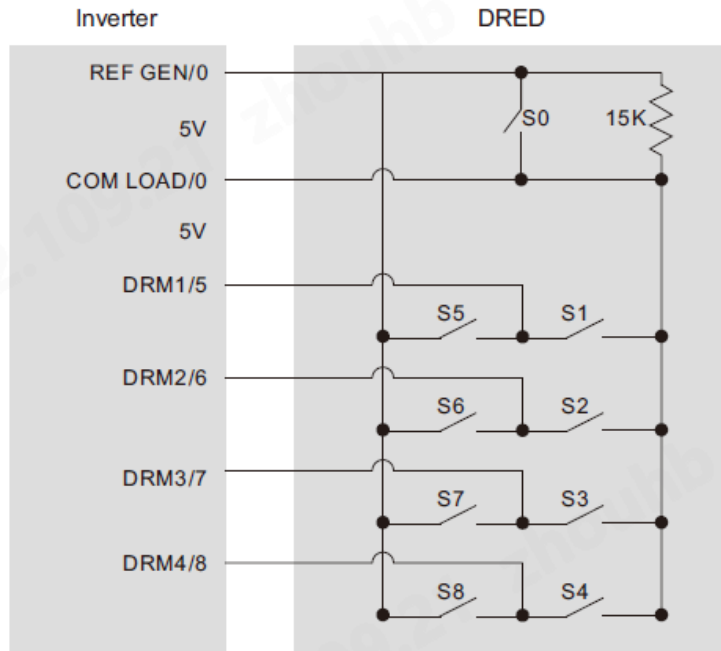

The DRM interface pins are defined as follows:

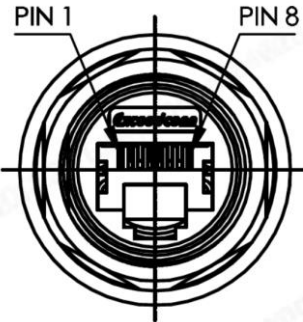
	Pin position	Network
		1
	2	DRM2/6
	3	DRM3/7
	4	DRM4/8
	5	REF GEN/0
	6	COM LOAD/0
	7	V+
	8	V-

Demand response modes (DRMs)

Mode	Requirement
DRM 0	Operate the disconnection device
DRM 1	Do not consume power
DRM 2	Do not consume at more than 50 % of rated power
DRM 3	Do not consume at more than 75 % of rated power AND supply reactive power if capable

DRM 4	Increase power consumption (subject to constraints from other active DRMS)
DRM 5	Do not generate power
DRM 6	Do not generate at more than 50 % of rated power
DRM 7	Do not generate at more than 75 % of rated power AND absorb reactive power if capable
DRM 8	Increase power generation (subject to constraints from other active DRMs)

For further assistance, please refer to the product manuals of KAC50DP2 and BC197DE2, or contact the local Kstar technical support team or email to Support@kstar.com.

## 5.2 Installation process

The installation process of KAC50DP2 Power Conversion System is as follows:

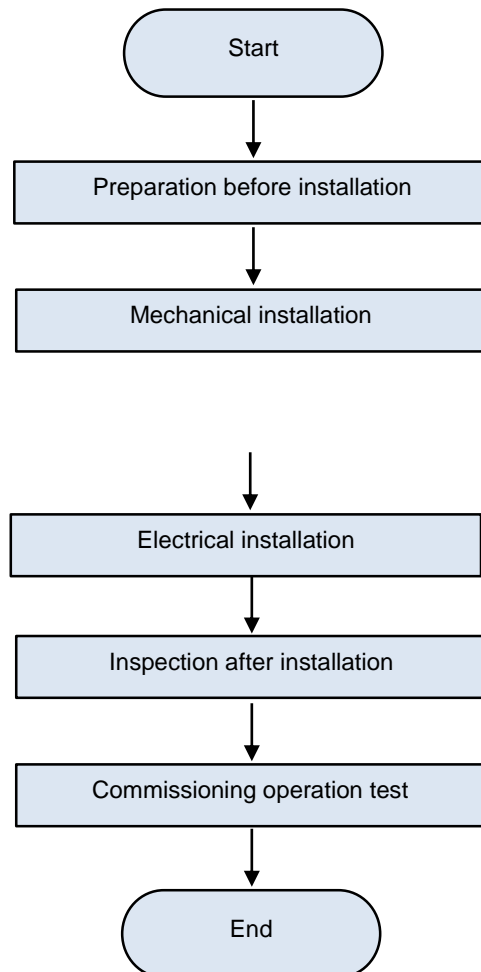

Figure 5-1 Installation Process Diagram



## 5.3 Installation Preparation

### 5.3.1 Packaging inspection

It is necessary to check the equipment for damage before installation. If you discover any transportation damage, please contact the shipping company or Shenzhen Kstar New Energy Co., Ltd. and provide photos of the damaged areas.

### 5.3.2 Inspection of delivery list

Check whether all accessories delivered are complete according to the packing list in the packing case:



Converter User Manual Certificate of Conformity Warranty Card

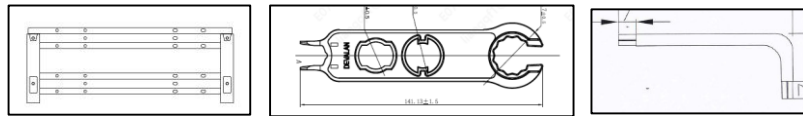

Mounting bracket PV wrench L-shaped wrench



AC terminal M10 screw and nut M6 screw

Figure 5-2 Illustration of Delivery List

Table 5-1 Delivery List

SN	Item	Quantity
1	Converter	1PCS
2	User Manual	1PCS
3	Certificate of conformity	1 PCS
4	Warranty card	1 PCS
5	AC terminal block	15 PCS
6	Mounting bracket assembly (2 mounting brackets and 2 beams)	1PCS
7	Bolt (M10*30)	12PCS
9	Bolt (M6*35)	2PCS
10	Wrench (for PV connector removal)	1 PCS
11	L-shaped wrench (for cover removal)	1 PCS

### 5.3.3 Inspection of accessories list

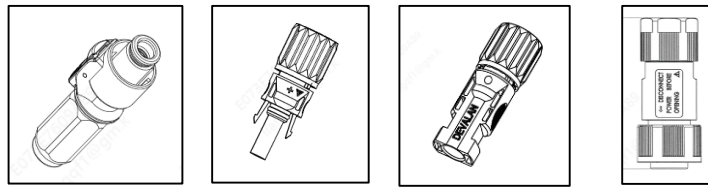

Battery terminal PV positive terminal PV negative terminal COM/DRY terminal

Figure 5-3 Illustration of Optional Accessories

SN	Item	Quantity
1	External battery connection terminal (positive)	2PCS
2	External battery connection terminal (negative)	2PCS
3	External PV connection terminal (positive)	8 PCS
4	External PV connection terminal (negative)	8 PCS
5	COM terminal	1PCS
6	DRM terminal	1PCS
7	DRY terminal	1PCS
8	Parallel terminal	2PCS
9	RJ45 network cable	1PCS

### 5.3.3 Installation tools and parts

The tools and parts required for installing the converter are as follows, which are not included into the list of accessories and options supplied with the products and need to be prepared by the customer or on site:

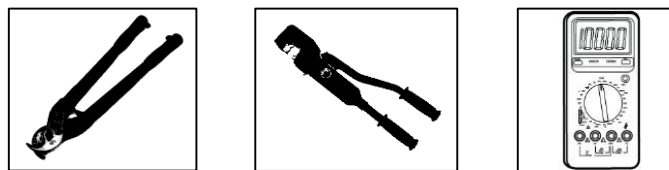

Wire stripper Crimping plier Multimeter

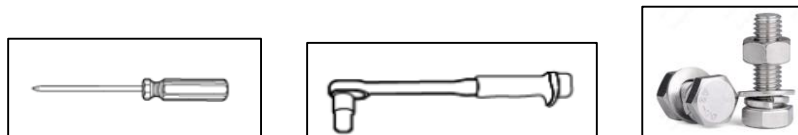

Screwdriver Socket wrench Spare screws

Figure 5-4 Illustration of Tools

Table 5-3 List of Tools

Tools	Remarks
Stripping and cutting pliers	1 pcs
Terminal crimping pliers	1 pcs

---

Screwdriver	1 set
Sleeve	1 set
Multimeter	1 set
Screws, nuts, and washers	Several

### 5.3.4 Installation Environment Requirements

Before installing the converter, please confirm the following environmental requirements:

Table 5-4 Environment Requirements

Item	Requirements
Temperature	-20°C ~ +50°C
Humidity	<90% (no condensation)

## 5.4 Machine Transportation



### 5.4.1 Transportation Instructions

- In order to keep the converter in a better protective state, packaged transportation shall be adopted as much as possible.
- When using a forklift or crane for transportation, it is necessary to pay attention to the weight of the converter, ensure that the transportation equipment has sufficient bearing capacity, and arrange the support or lifting points reasonably.
- The outer package of the converter is marked with detailed product parameters and transportation requirements. Please transport according to the schematic diagram of various identifications on the package. The graphic description of the converter package identification is shown in Tables 5-4 and 5-5:

Table 5-4 Description of Packaging Parameters

Name	Description
MODEL	Converter model
SIZE	Outer packaging size
NW	Net weight of converter
GW	Gross weight, converter including outer packing case

Table 5-5 Illustration of Package Identification

Signs	Description
	With the front side up, it is forbidden to place the converter horizontally, tilt or invert it
	Handle with care to avoid damage to the converter due to excessive collision and friction in the transportation environment
	Pay attention to moisture prevention and avoid the converter from being exposed to rain or moisture

## 5.5 Positioning and Fixing

### 5.5.1 Space Requirements

- Installed indoors/outdoors with good ventilation. No over-humidity, high temperature source, and no corrosive gas.
- Ensure that the ground wire in the power distribution room is well grounded, and the grounding resistance shall be less than  $4\Omega$  in a dry environment.
- The converter shall be wall-mounted, installed on the side of the battery cabinet or on the wall, and sufficient bearing capacity shall be ensured.
- The converter shall be installed perpendicular to the ground, and the inclination angle of the front, rear, left and right shall be less than  $3^\circ$ .
- Avoid being placed together with flammable and explosive materials to meet fire protection requirements.
- The space reserved size is shown in the figure below:

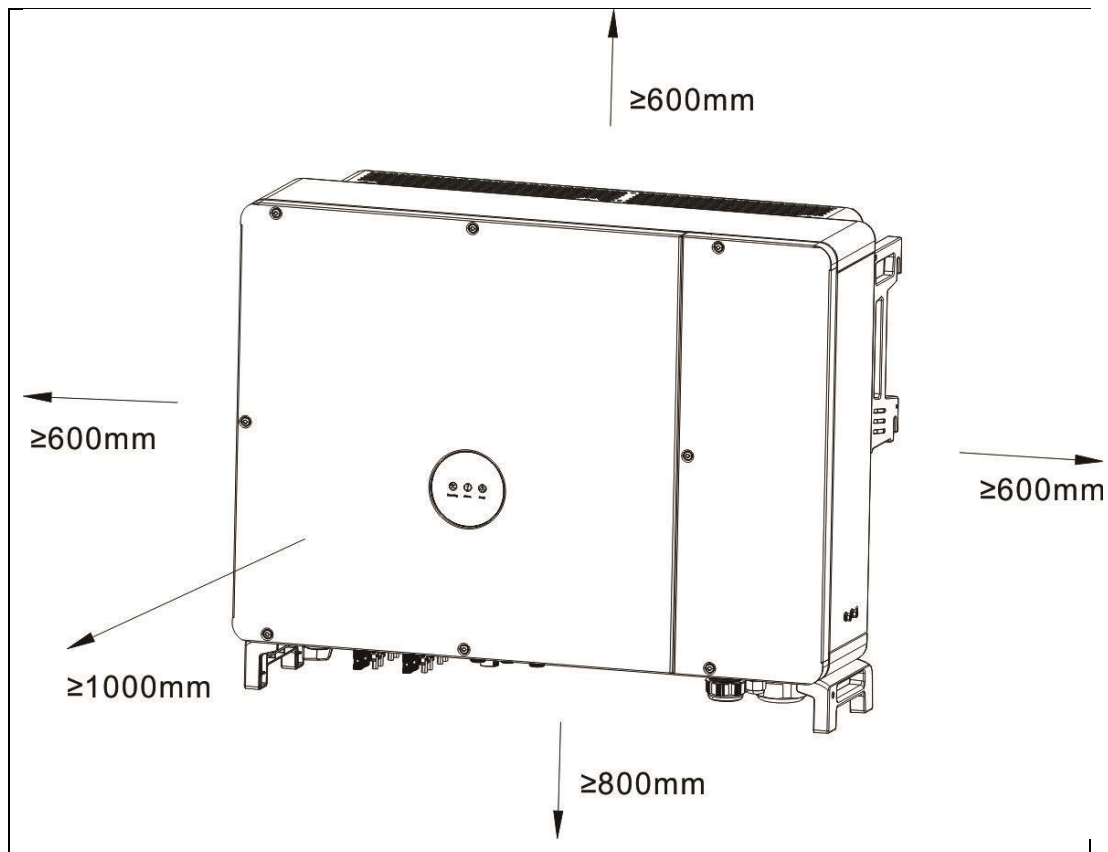

Figure 5-4 Diagram of Reserved Space Size

### 5.5.2 Model Size

The mechanical dimensions of the KAC50DP2 converter model are shown in the figure below, and users can design and install according to this data.

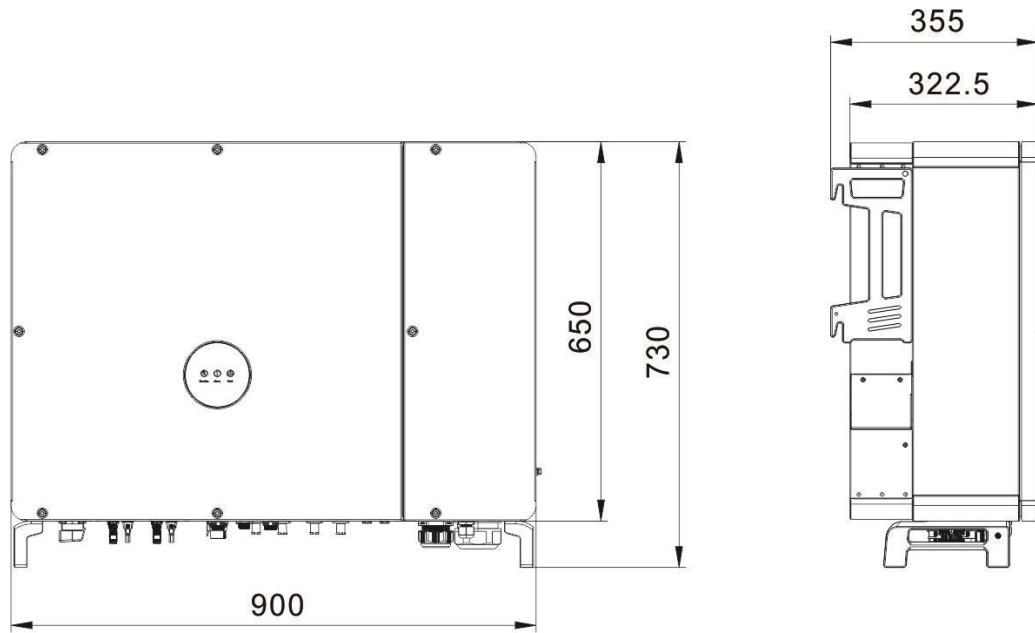

Figure 5-5 KAC50DP2 Model Dimensions

### 5.5.3 Hanger installation

The bottom of the KAC50DP2 converter needs to be securely connected to the foundation surface. There are fixing holes at the bottom of the converter for fixing, which are used to fix the converter on the bottom support channel steel or wall after it is in place. As shown in the figure below:

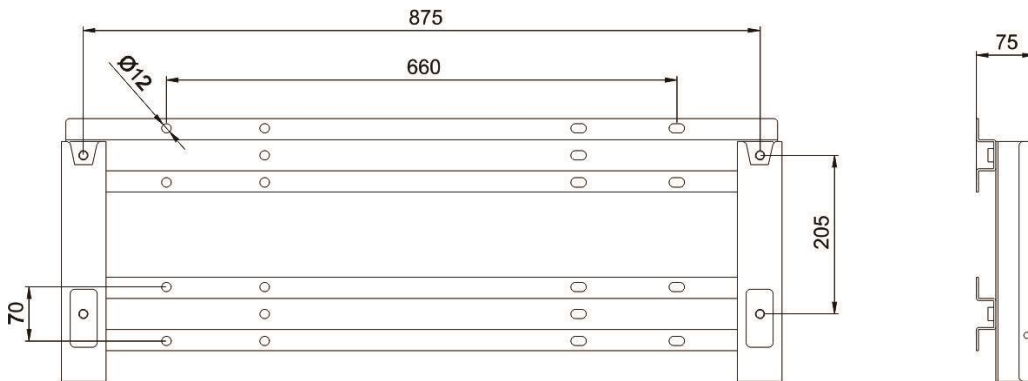
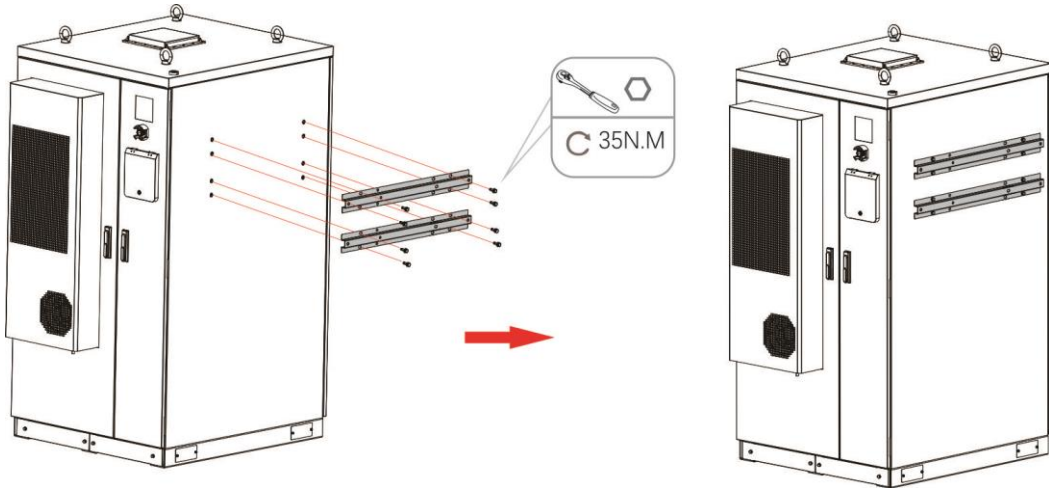

Figure 5-6 Mounting and Fixing of Hanger

## 5.6 Installation of Power Conversion System in the battery cabinet

**Step 1:** Take out 2 beams and fix them to the side of the battery cabinet using 8 M10\*30 screws.



**Step 2:** Take out the converter back plate\*1 and M10\*30 screws\*4, and fix the back plate to the beam.

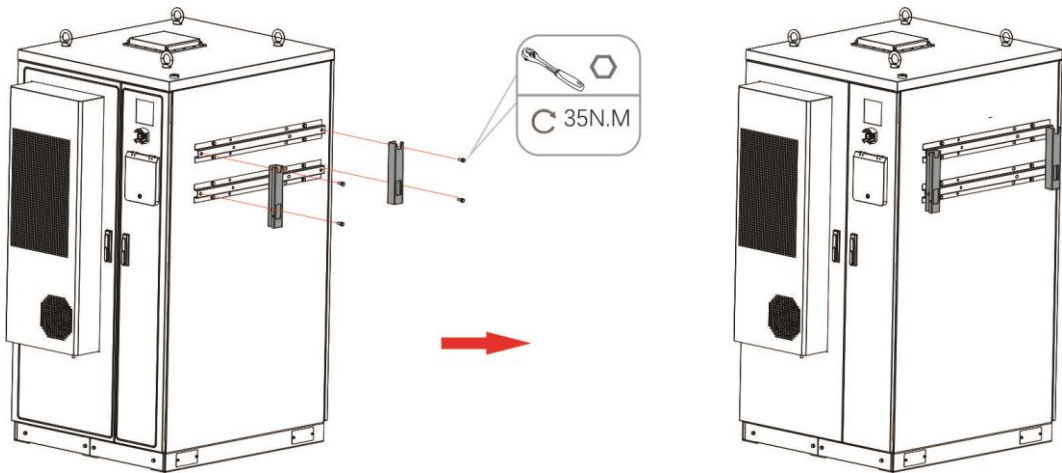

**Step 3:** Place the converter on the back plate and make sure it is properly installed; Then tighten the following two M6\*16 screws on the side to ensure a firm connection between the converter and the battery cabinet.

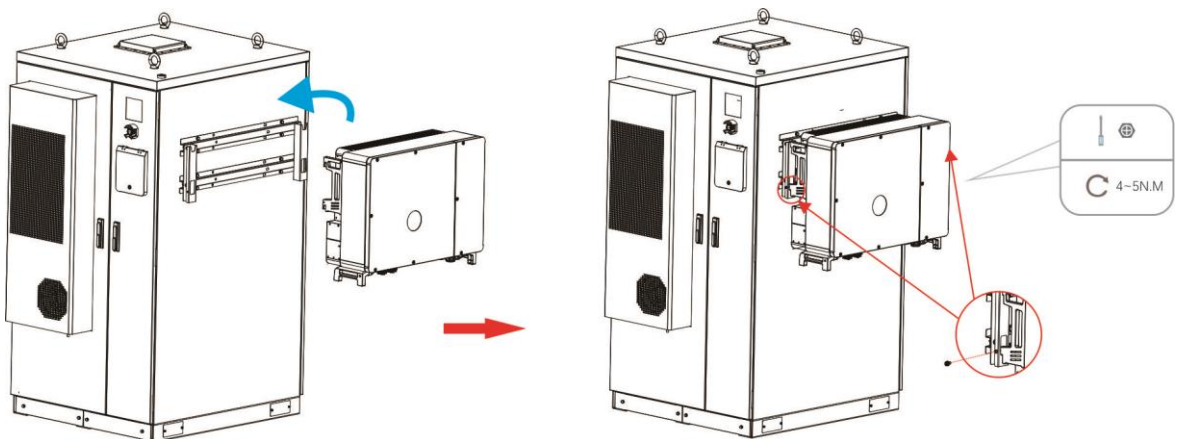

## 5.7 Air Duct Design and Installation

### 5.7.1 Forced Air Cooling System

The KAC50DP2 Power Conversion System provides forced air cooling for heat dissipation.

### 5.7.2 Ventilation Environment

In order to meet the ventilation requirements of the KAC50DP2 converter, its installation environment shall meet the following requirements:

- The converter shall not be installed in places with poor ventilation conditions and low air flow.
- The air inlet shall have sufficient space and the air outlet shall have sufficient space to discharge the hot air flow.

The schematic diagram of air inlet and air outlet is shown in the figure below.

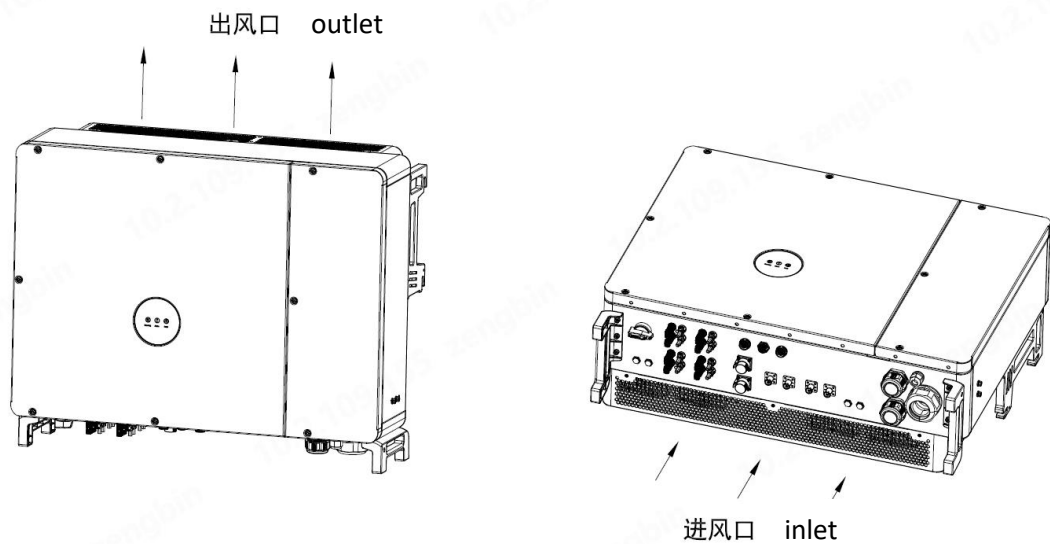

Figure 5-7 Schematic Diagram of Air Inlet and Outlet

## 6 Electrical Installation Guidance

### 6.1 Cable requirements

According to the capacity configuration requirements of a single KAC50DP2 converter, it is recommended that the current passing through the  $1\text{mm}^2$  wires should not exceed 6A, and the same specification and type of wires should be selected for the connecting wires on the same side. Kstar has provided reference requirements for various interface cables. Users can design relevant cables according to the following table. Cables shall be designed in accordance with the instructions in this section and local wiring regulations, taking into account environmental conditions.

Table 6-1 Specifications of KAC Converter Power Cables

Connection equipment	Maximum current of single wire	Recommended wire diameter $\text{mm}^2$	Recommended wire diameter AWG
PV	DC 24A	4~6 $\text{mm}^2$	9~11AWG
Battery	DC 80A	20~35 $\text{mm}^2$	2~4AWG
GRID port	AC 160A	$\geq 34 \text{ mm}^2$	$\geq 2\text{AWG}$
LOAD port	AC 110A	20~35 $\text{mm}^2$	2~4AWG
GEN port	AC 110A	20~35 $\text{mm}^2$	2~4AWG
Earthing wire	/	10~16 $\text{mm}^2$	5~7AWG

※ It is recommended to use the switch with rated current  $\geq 125\text{A}$  and rated voltage  $\geq 400\text{Vac}$  for the external switch of the LOAD/GEN port on the three-phase AC side.

※ It is recommended to use the switch with rated current  $\geq 200\text{A}$  and rated voltage  $\geq 400\text{Vac}$  for the external switch of the GRID port on the three-phase AC side.

※ The battery cabinet on the battery input side is equipped with a switch.



- The cable sizes provided in this table are for reference only. The actual selection should be based on the cable working environment temperature, laying method, heat dissipation conditions, docking terminals, etc.
- The recommended wire is copper wire, and aluminum wire is not supported. It is recommended to use multi-core flexible wires that are easy to bend, and it is not recommended to use single-core wires or hard wires that are not easy to bend.

#### Warning

Before wiring operation, confirm that the mains supply, PV switch and battery switch are all disconnected, and affix warning signs to prevent others from operating the switch.

#### Warning

Power cables need to be routed through trenches or trunking to avoid mechanical damage to cables or radio frequency interference to peripheral equipment.

## 6.2 Wiring Specifications

When laying cables, the communication cables and power cables shall be laid separately. The DC circuit and AC circuit shall be laid separately, and the distance between different cables shall be greater than 30 mm. When the control cable must pass through the power cable, ensure that the angle between the two cables is kept at 90° as much as possible.

The recommended minimum space distance between the parallel shielded data cable and the power cable corresponds to the field.

Table 6-2 Wiring Spacing between Signal Cable and Power Cable

Parallel cable length (m)	Minimum space distance (m)
200	0.3
300	0.5
500	1.2

※ The data cable shall be routed as close as possible to the ground support, such as support beams, steel channels, metal guide rails, etc.

## 6.3 Fixation and protection of connecting cables

### 6.3.1 Fixing of cables

In order to prevent the copper nose of the wiring from loosening under stress, causing poor contact, or increasing contact resistance, resulting in heating or even fire, make sure that the screws fastening the terminal meet the following torque requirements:

Screw torque values are referenced as follows:

#### AC output terminal:

Recommended torque for diesel engine and load: 3.5N.m, 10mm socket;  
 Recommended torque for mains supply: 10N.m, 13mm socket;

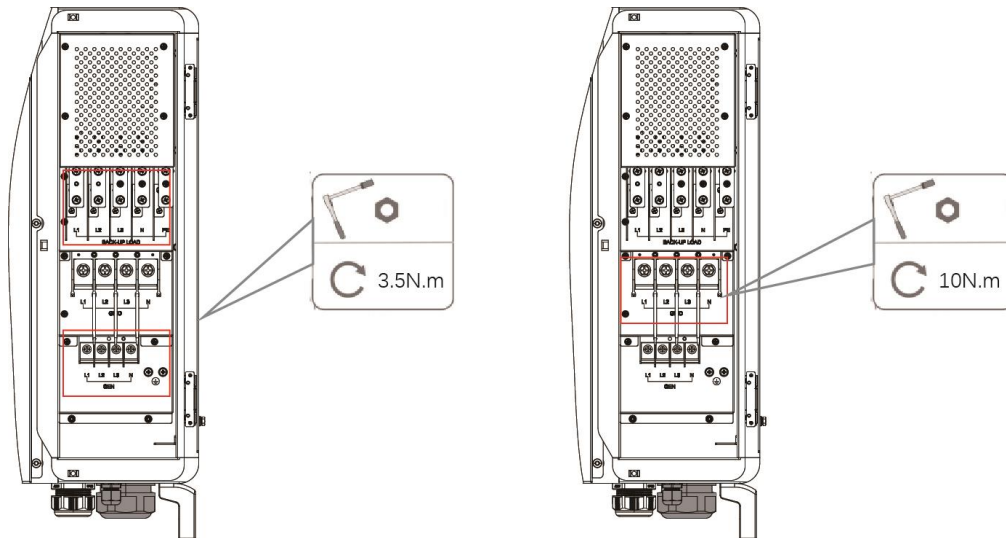

Lock hanger:

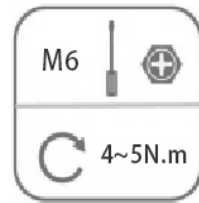
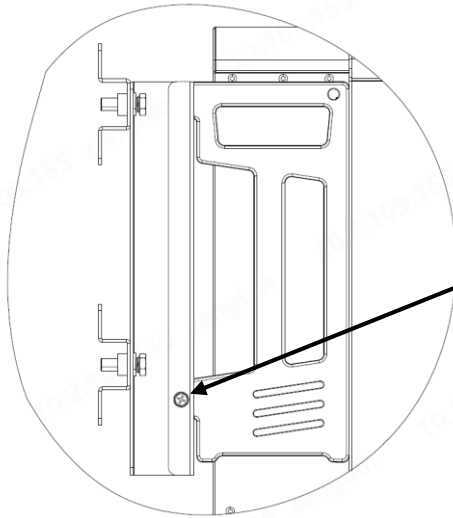
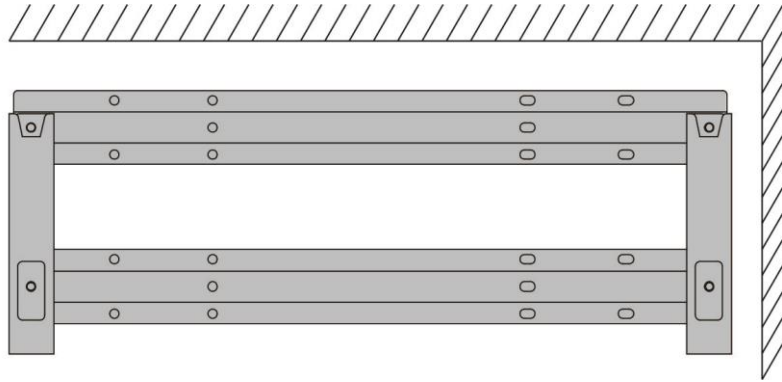

**Earthing:**

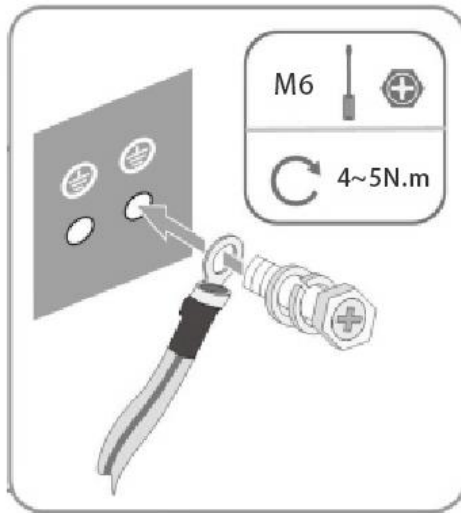

### 6.3.2 Protection of Cables

The protection of cables includes communication cables and power cables. The protection methods are as follows:

Protection of communication cables: Since communication cables are thin and easy to be broken or fall off from the terminals during construction, it is recommended to connect the power circuit before connection. During connection, try to route the cable trough, and fasten the place without cable trough with cable ties. During routing, the heating element and strong electric field circuit cables should also be avoided.

Protection of power cables: Therefore, scratches and damage to the cable insulation shall be avoided during installation and connection, as this may cause short circuit. Power cables should also be properly secured.

## 6.4 Opening terminal box

Step 1: Remove the two screws on the terminal box using the Allen key from the shipping accessories.

Step 2: Open the terminal box.

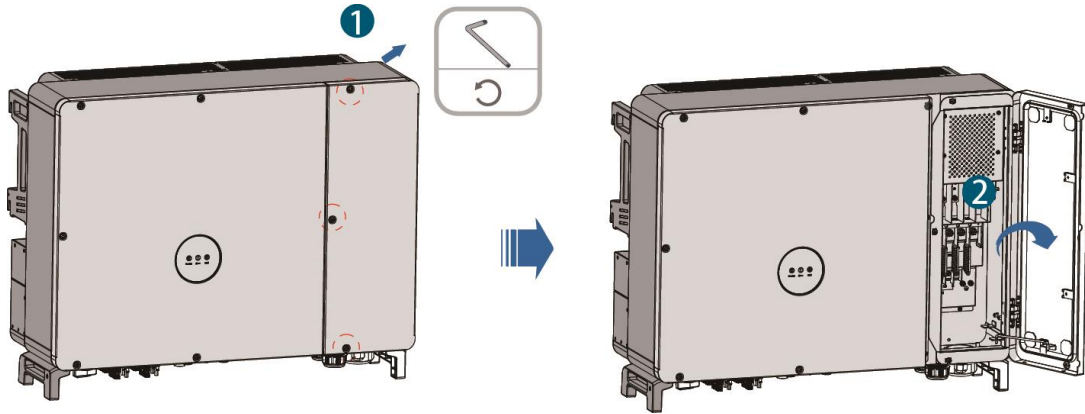

Step 3: Use the limit bar on the terminal box cover to fix its position for easy wiring operation.

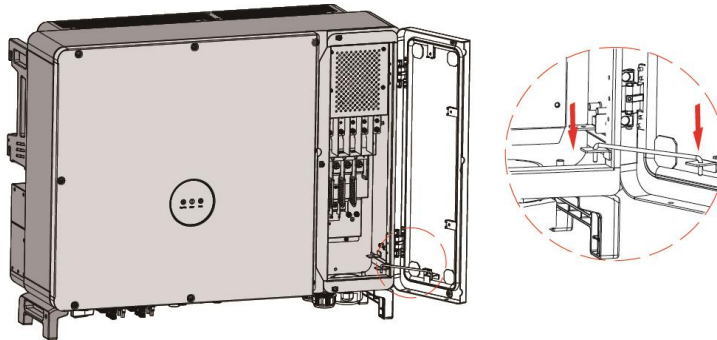

After the wiring is completed, close the terminal box in the reverse order.

## 6.5 DC side wiring

### 6.5.1 PV side connection

The DC side wiring of PV modules connected to KAC50DP2 converter is shown in Table 6-4 below.

There are 4 MPPT channels in total. The MPPT voltage access range is 250V~1000V, and the maximum DC current of each MPPT channel is 45A. The maximum PV input power of a single KAC50DP2 converter is 100KW. Refer to Section 6.5 for wiring port access locations.

Table 6-3

PV+	To the positive pole of the PV array
PV-	To the negative pole of the PV array

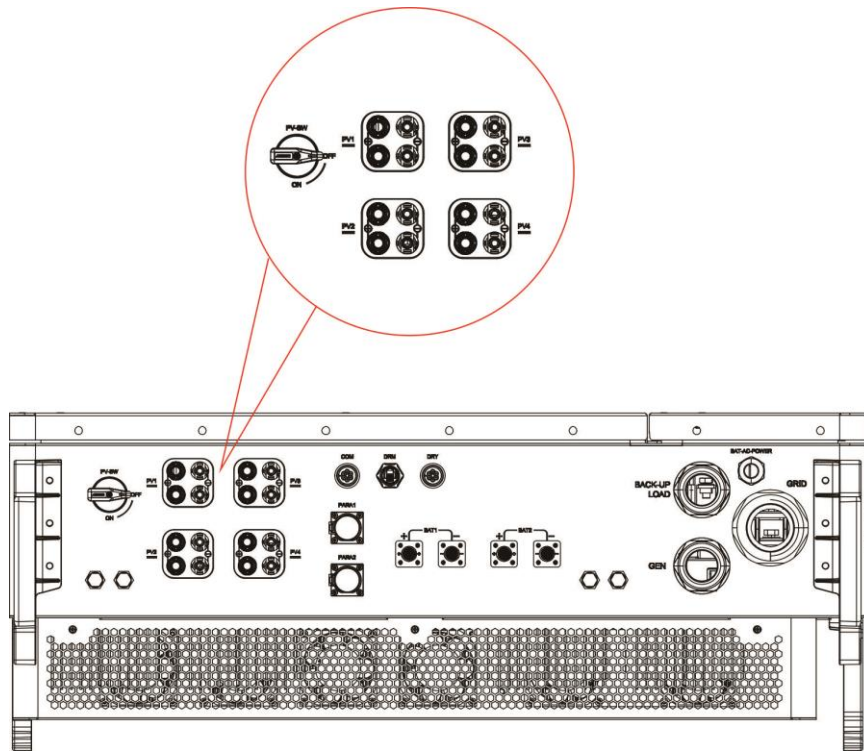

Figure 6-1 PV Connection Terminal 4-way

### 6.5.2 Battery side connection

The DC side wiring relationship between the battery and the KAC50DP2 converter is shown in Table 6-5 below.

The battery voltage access range is 250V~950V, and the maximum two-way DC total current is 160A. The power of a single KAC50DP2 converter shall not exceed 1.1 times the rated power. Refer to Section 6.5 for wiring port access locations.

Table 6-4

BAT+	To the positive pole of the battery pack
BAT-	To the negative pole of the battery pack

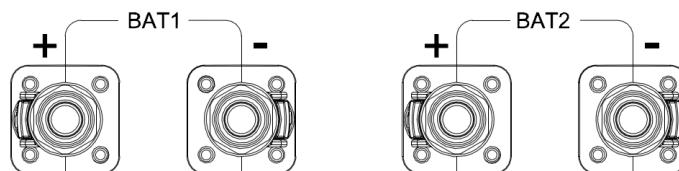

Figure 6-2 Battery Connection Terminal

### 6.5.3 DC side wiring

The steps are as follows:

**Step 1:** Use a multimeter to confirm that all terminals of the converter are powered off.

**Step 2:** Confirm the positive and negative poles of the cable and mark them.

**Step 3: Connect and install the DC connector**

Step 1: Strip the insulation layer of all DC cables by about 7 mm.

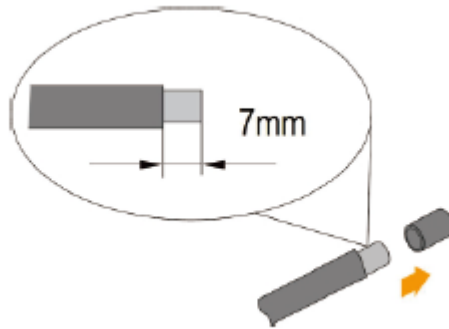

Step 2: Cluster the cable ends to the wiring terminals with crimping pliers.

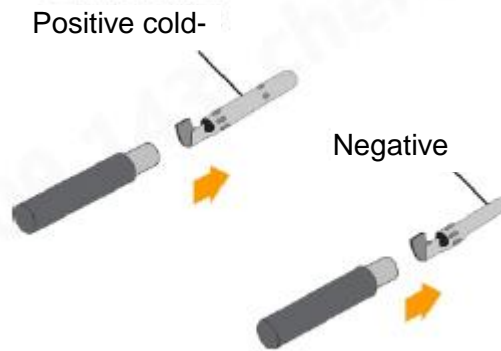

Step 3: Pass the cable through the cable gland and insert the insulating sleeve until it snaps. Gently pull the cable to ensure it is securely connected.

Tighten the sealing sleeve and the insulating sleeve with a force of 2.5~3 N·m.

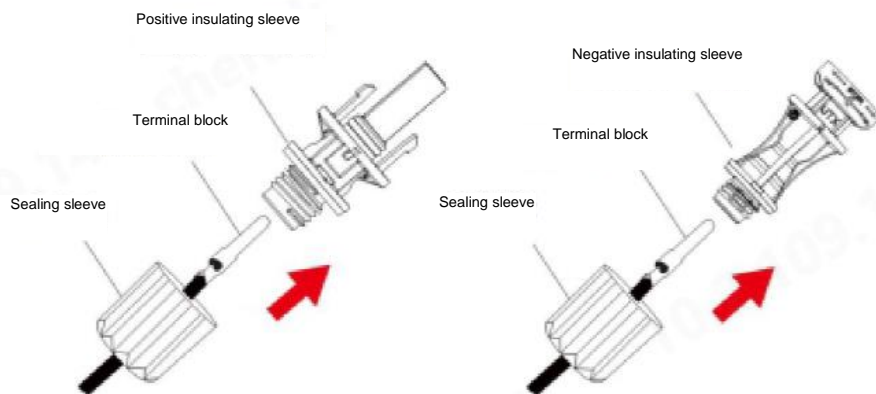

Step 4: Connect the positive and negative poles of the PV array to the "PV+" and "PV-" terminals.

**⚠ Attention**

Before connecting the DC connector, make sure that the DC switch is turned off, check whether the polarity of the connecting cable of the PV string is correct, and ensure that the open circuit voltage does not exceed the upper limit of the inverter input of 1000V in any case.



Step 5: Insert the DC connector into the corresponding DC terminal until a "click" sound is heard.

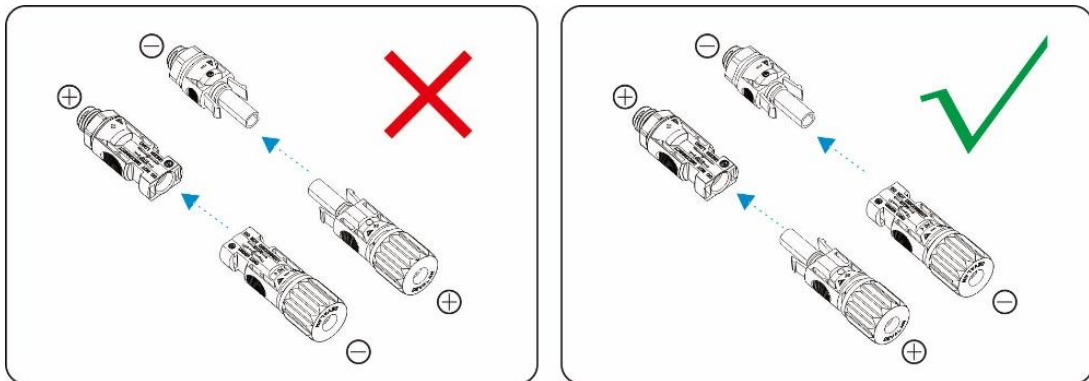

Before connecting the DC connector to the inverter, check the positive and negative polarity of the battery board

Insert the DC connector into the corresponding DC terminal; If the DC connector is not assembled in place, it may cause arcing or overheating of the connector, and the resulting damage will not be covered by the warranty.

**Step 4:** Connect the positive and negative terminals of the battery pack to the "BAT+" and "BAT-" terminals.

**⚠ Danger**

In order to avoid personal injury and equipment injury, the wiring must be carried out without electricity.

- The DC switch is disconnected.
- Use a multimeter to measure that the DC side terminal block is not live.

**⚠ Warning**

DC voltage limits. Make sure the PV voltage does not exceed 1000VDC! The battery voltage does not exceed 950VDC!

- Any DC voltage exceeding the limit may cause damage to the converter.
- The equipment damage and loss caused in this case are not covered by the

warranty.

## 6.6 AC side wiring

### 6.5.1 AC connection (4 interfaces)

The KAC50DP2 Power Conversion System can be directly connected to the grid, with either three-phase four-wire or three-phase five-wire. The A/B/C phases of the converter shall correspond to the phase sequence of the grid A/B/C phase one by one without phase staggering. The corresponding relationship is shown in the following table.

Table 6-5 Correspondence of AC Connection

AC terminal	Grid	Cable reference color
L1	To grid phase A or U	Yellow
L2	To grid phase B or V	Green
L3	To grid phase C or W	Red
N	To grid phase N	Blue or black
PE	Safety earthing	Yellow turning green

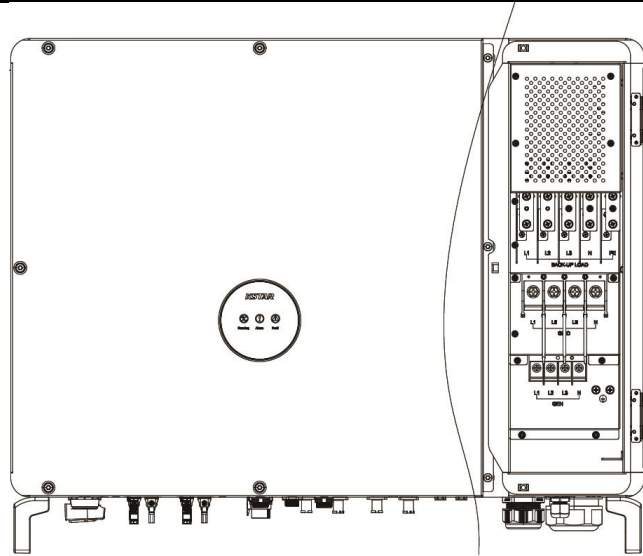

Figure 6-3 AC Connection Terminals on the Converter

### 6.6.2 AC side wiring steps

**Step 1:** Use a multimeter to measure and confirm that all terminals are powered off.

**Step 2:** Confirm the cable phase sequence and mark the cables. The AC output three-phase cables L1, L2, L3, N and PE shall be yellow, green, red, black/blue and yellow-green cables respectively to distinguish the phase sequence.

**Step 3:** Connect the ABC (UVW) phases of the grid to the converter correctly according to Table 6-5.



1. Recommended circuit breaker parameters: 4P 200A/690VAC
2. Recommended leakage protection switch: leakage current 300mA

There is a small waterproof port on the waterproof cover of the AC connection port, which is used to connect the voltage of 220V AC to power the A/C and other equipment. It can be connected to 5mm<sup>2</sup> two-core or three-core cables.

AC terminal	Grid	Line voltage	Remarks
L1 or L2 or L3	To grid phase A/B/C	220V AC	KAC50DP2/KAC50D2 (with STS) series A/C L and N are connected to L1/L2/L3 and N of Load;
N	Neutral line	0V AC	
PE	Safety earthing		KAC50DP2-S0/KAC50D2-S0 series A/C L and N are connected to L1/L2/L3 and N of GRID

**Step 4:** Peel off a certain length of the protective layer and insulation layer as shown in the diagram.

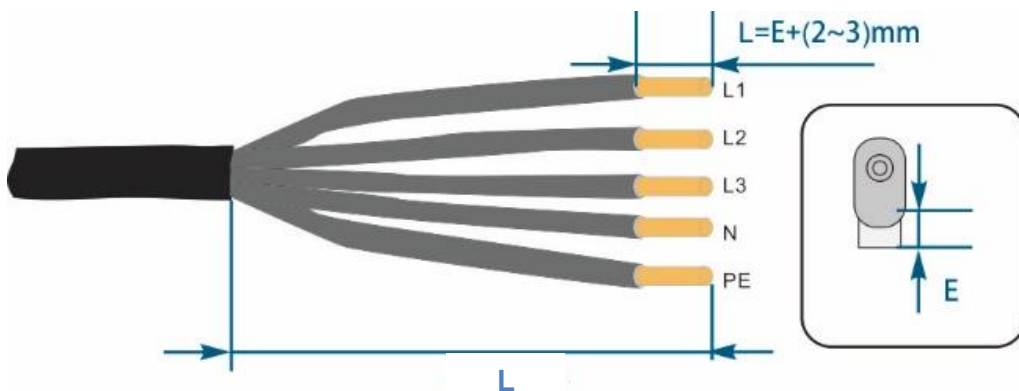

L	Unit (mm)
Stripping cable length of load	≤330mm
Stripping cable length of mains supply	≤240mm
Stripping cable length of diesel engine	≤130mm

**Step 5:** Make cables and crimp terminals.

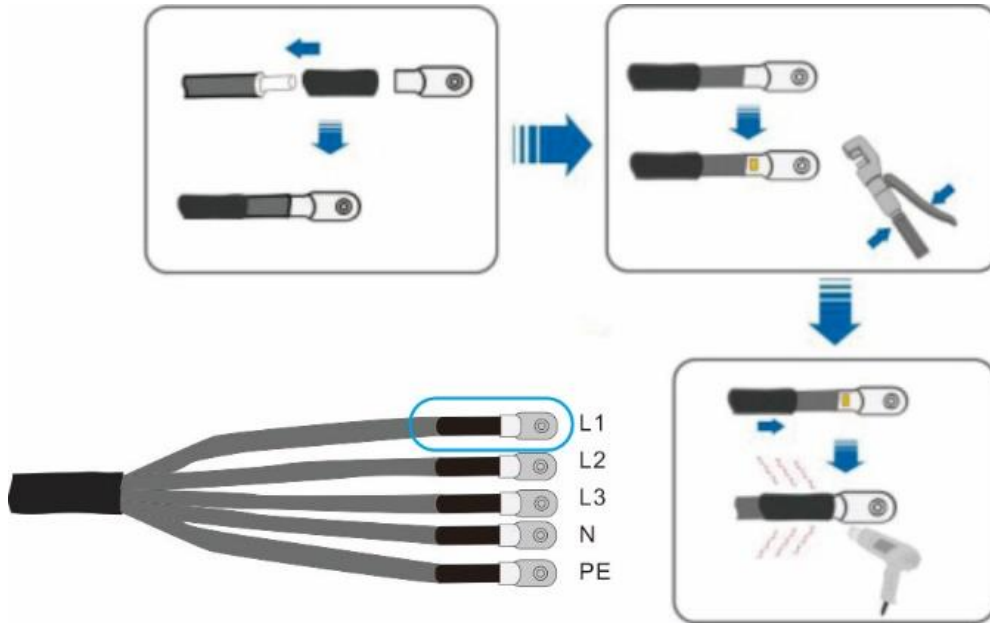

**Step 6:** Secure the cables to the corresponding terminals.

**⚠ Attention**

Location of "PE" cable and "N" cable. If the phase line is connected to the terminal of "PE" or "N" cable, it may cause permanent damage to the inverter.

**Grid wiring diagram:**

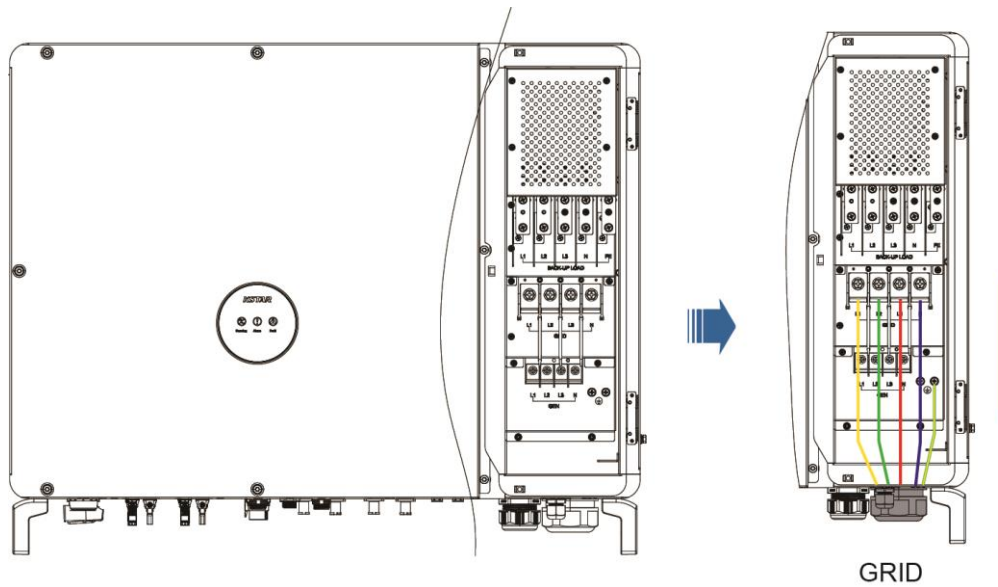

**Load, GEN and A/C wiring diagram:**

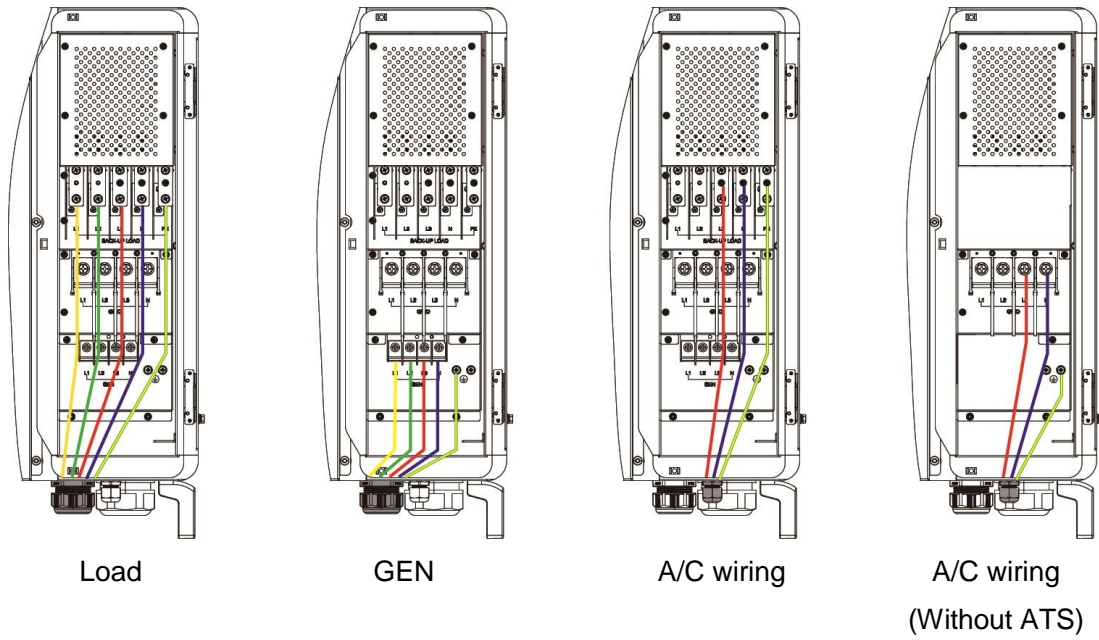

**Step 7:** Gently pull the cable backwards and tighten the locking nut clockwise.

Recommended torque and tools for load and diesel engine: 10-13N.m, 53mm wrench;

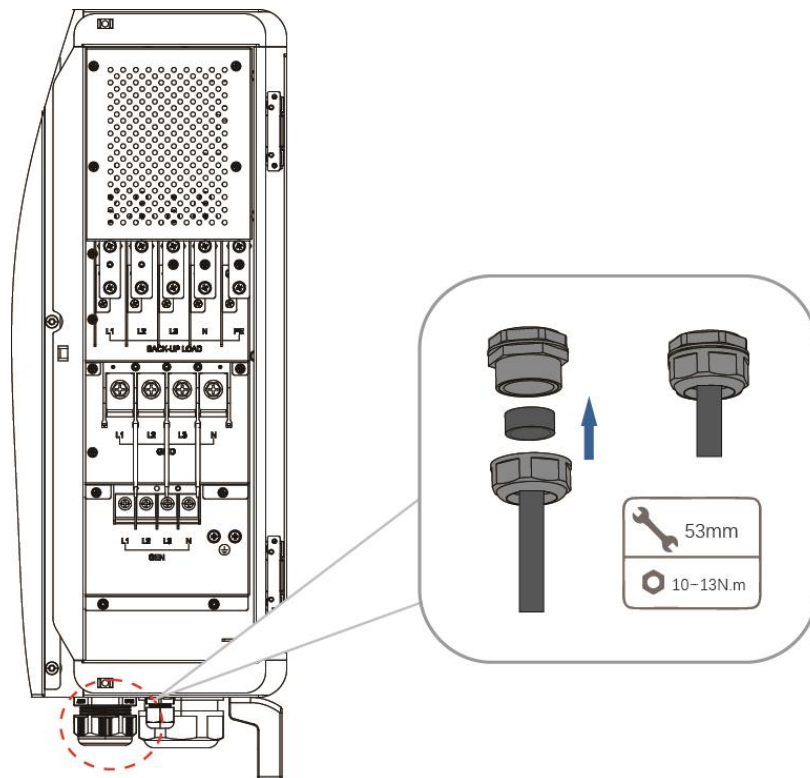

Recommended torque and tools for mains supply: 11-14N.m, 72mm wrench;

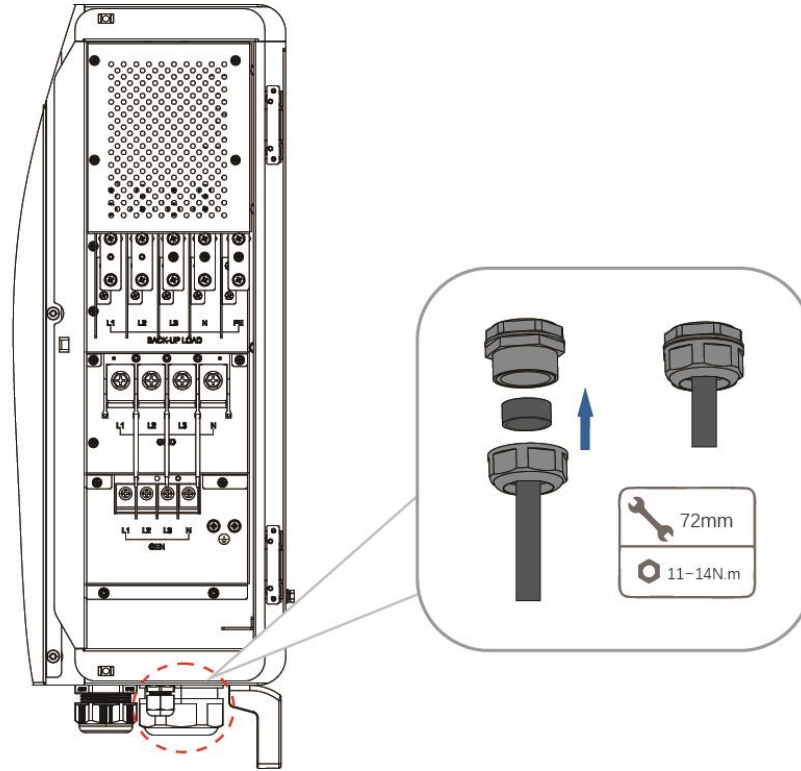

## 6.7 Communication interface

### 6.7.1 PARA Connection and COM Port Connection

KAC50DP2 has two external parallel communication interfaces: PARA1, which is used for hand-in-hand communication when two or more PCSs are parallel. The inside of the parallel interface is in parallel connection, with the same pins. The pin network is shown in the following table:

**Table 6-6** Correspondence of PARA Connection for Parallel Interface:

Pin position	Network
1	/
2	/
3	CAN-H
4	CAN-L
5	Zero-crossing synchronization
6	EPO
7	Carrier synchronization
8	GND

**Table 6-7** Correspondence of COM Port Connection:

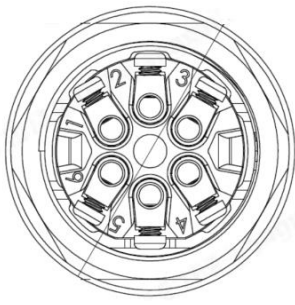
	Pin position	Network
	1	RS485-H
	2	RS485-L
	3	CAN-H
	4	CAN-L
	5	CANBMS-H
6	CANBMS-L	

**Table 6-8** Correspondence of DRY Port Connection:

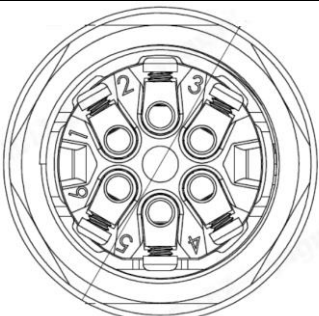
	Pin position	Network
	1	DRY1
	2	DRY2
	3	/
	4	GND
	5	DRY-CONTACT3
6	/	

### 6.7.2 DRM Response Modes

The KAC20-50DP2 complies with AS/NZS 4777.2:2020 standard. Its DRM port can be connected to a Demand Response Enabling Device (DRED) in Australia or New Zealand or a Radio Ripple Control Receiver (RRCR) in other areas or countries.



When the Australia or the New Zealand grid standard is selected, the DRM port can be enabled to connect a DRED. When other grid standards are selected, this port can be enabled to connect an RRCR. For more information about grid standards, see [GRID CODE](#).

A DRM connector is necessary for the connection. [Table 6-9](#) shows the pin descriptions of the DRM connector.

**Table 6-9** Correspondence of DRM Port Connection:

Pin position	Network
1	DRM1/5
2	DRM2/6
3	DRM3/7
4	DRM4/8
5	REF GEN/0
6	COM LOAD/0
7	V+
8	V-

## 6.8 System grounding

The chassis of the KAC50DP2 Power Conversion System shall be reliably connected with grounding cables. The resistance shall not exceed  $4 \Omega$ , the diameter of the grounding cable shall not be less than 16, and the position shall refer to the internal wiring terminals in section 6.5. $\text{mm}^2$

## 6.9 Installation completion

Power-on operation is allowed only after all mechanical and electrical installations are completed and confirmed to be correct.

# 7 Commissioning Operation

## 7.1 Inspection before startup

Before commissioning operation, thoroughly check the installation of the equipment, especially whether the voltage at the DC and AC terminals meets the requirements of the converter, and whether the polarity and phase sequence are correct.

Check that all connections have met the requirements of the relevant standards and specifications. And whether the system is well grounded. The grounding resistance is of great significance to the safety of the whole system, and it must be confirmed that the grounding resistance meets the requirements before the first commissioning operation.

### Attention

Before the commissioning operation, make sure that all switches on the DC and AC sides are disconnected.

#### **Step 1:** Check the converter

A series of checks are required before the converter is powered on:

Check whether the installation and wiring of the converter are completed according to the contents of Chapters 5 and 6.

Make sure that the AC and DC switches are disconnected.

#### **Step 2:** Check the AC side voltage

Check whether the three phases of the converter are correctly connected to the three-phase sequence of the grid.

Check whether the phase voltage and line voltage are within the predetermined range and record the voltage value.

If possible, measure the total harmonic distortion (THD) of the voltage. If the harmonic distortion is large, the converter may not be able to operate.

#### **Step 3:** Check the DC side voltage

The battery side shall be connected to the converter from the battery pack to ensure that the input polarity of each battery pack is correct.

The PV side shall be connected to the converter from the PV module to ensure that the input polarity of each PV module is correct.

### Warning

DC voltage limits. Make sure the PV voltage does not exceed 1000VDC! The battery voltage does not exceed 950VDC!

#### **Step 4:** Check other contents

After completing the above inspections before startup, carefully check the following items to ensure that they are correct.

- All connections shall be made in accordance with Chapter 6 of this manual.
- The AC side and DC side switches are disconnected, that is, in the "OFF" position.

### Warning

Before startup, the equipment must be thoroughly and carefully inspected to ensure that all indicators meet the requirements before startup.

## 7.2 Basic Setting

### 7.2.1 Time and Time Zone Setting (if Applicable)

Notice:

If it's connected in internet, the time can syn from the internet.

Go to "Setting"- "Run Mode"- "Screen"

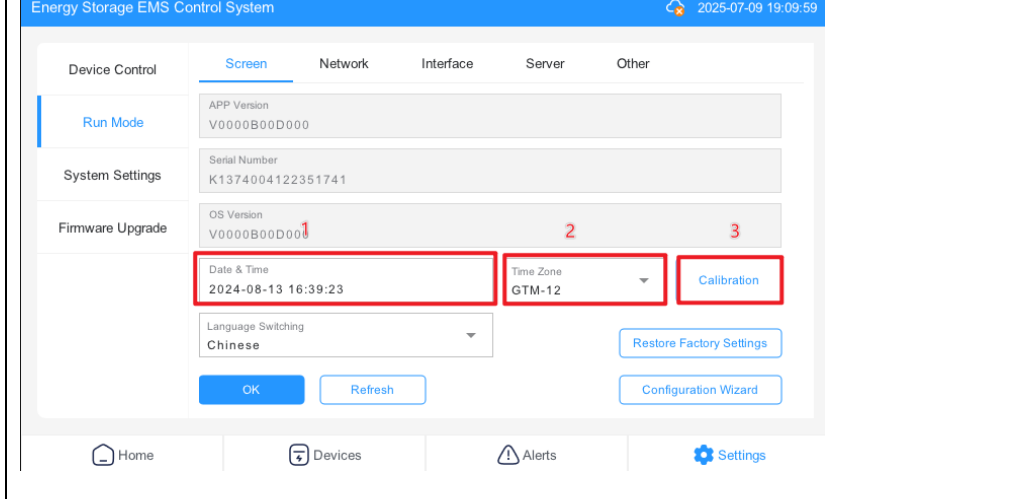

### 7.2.2 Grid Code Setting

Go to "Setting"- "Run Mode"- "Other"- "Grid Standard"

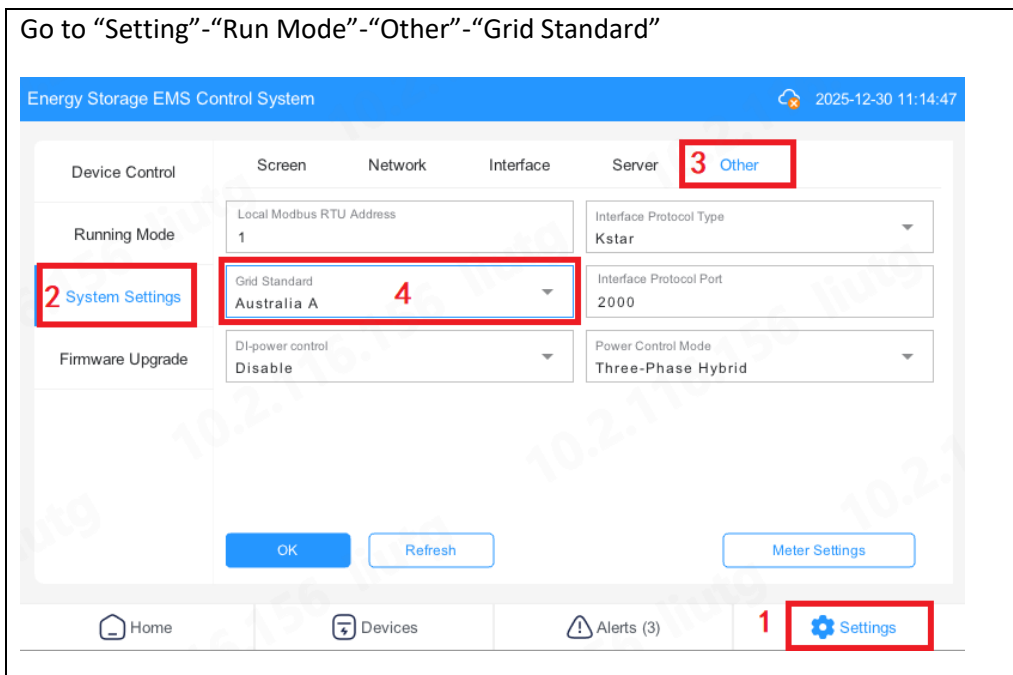

The image contains two screenshots of the Energy Storage EMS Control System interface. The top screenshot shows the 'Other' settings page with a 'Please Input a Password' dialog box overlaid on the 'Grid Standard' dropdown menu. The bottom screenshot shows the same page with the 'Grid Standard' dropdown menu open, displaying a list of options including 'Australia A', 'Ausgrid', 'Australia B', 'Australia C', and 'Endeavour'. The 'Australia A' option is selected with a blue checkmark.

**Note:** Changing the setting of Grid Standard is not recommended. Grid Standard are password protected. Please contact your installer or distributor for access.

### 7.2.3 Check software firmware version

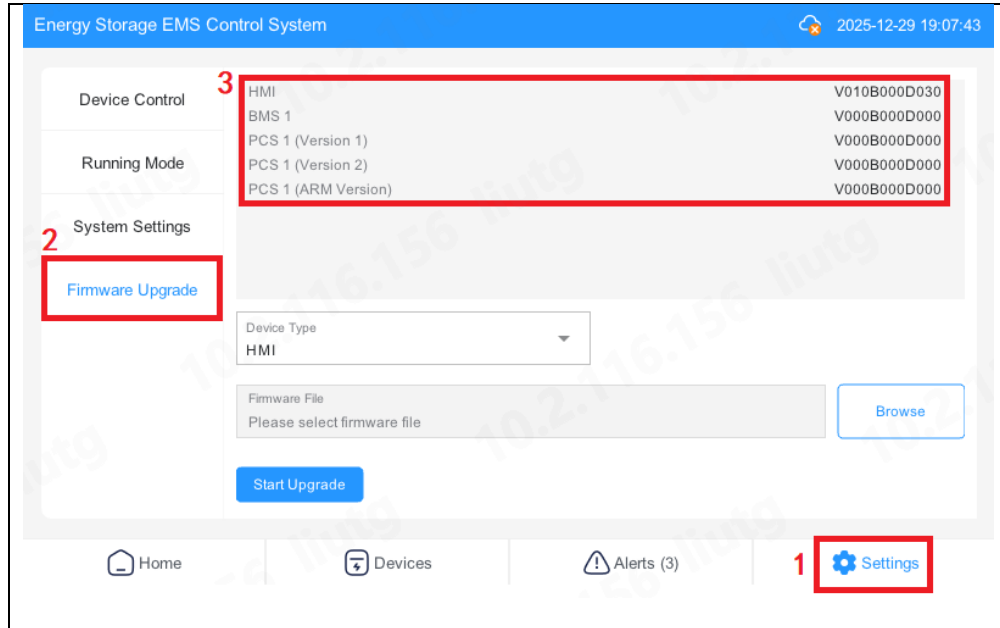

### 7.2.4 Over/under voltage and frequency Setting

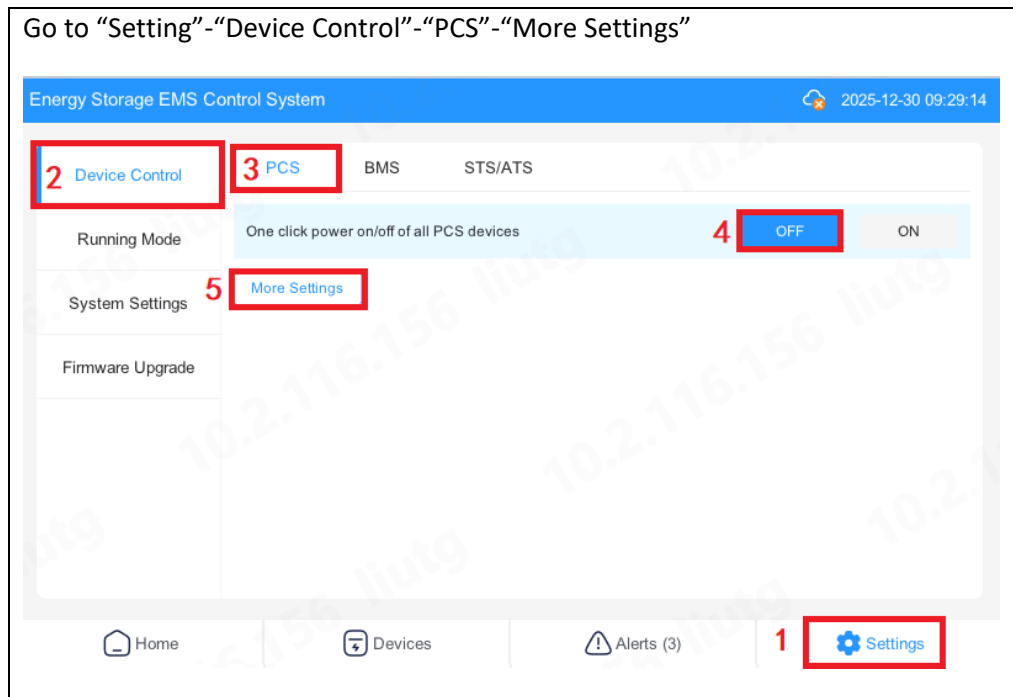

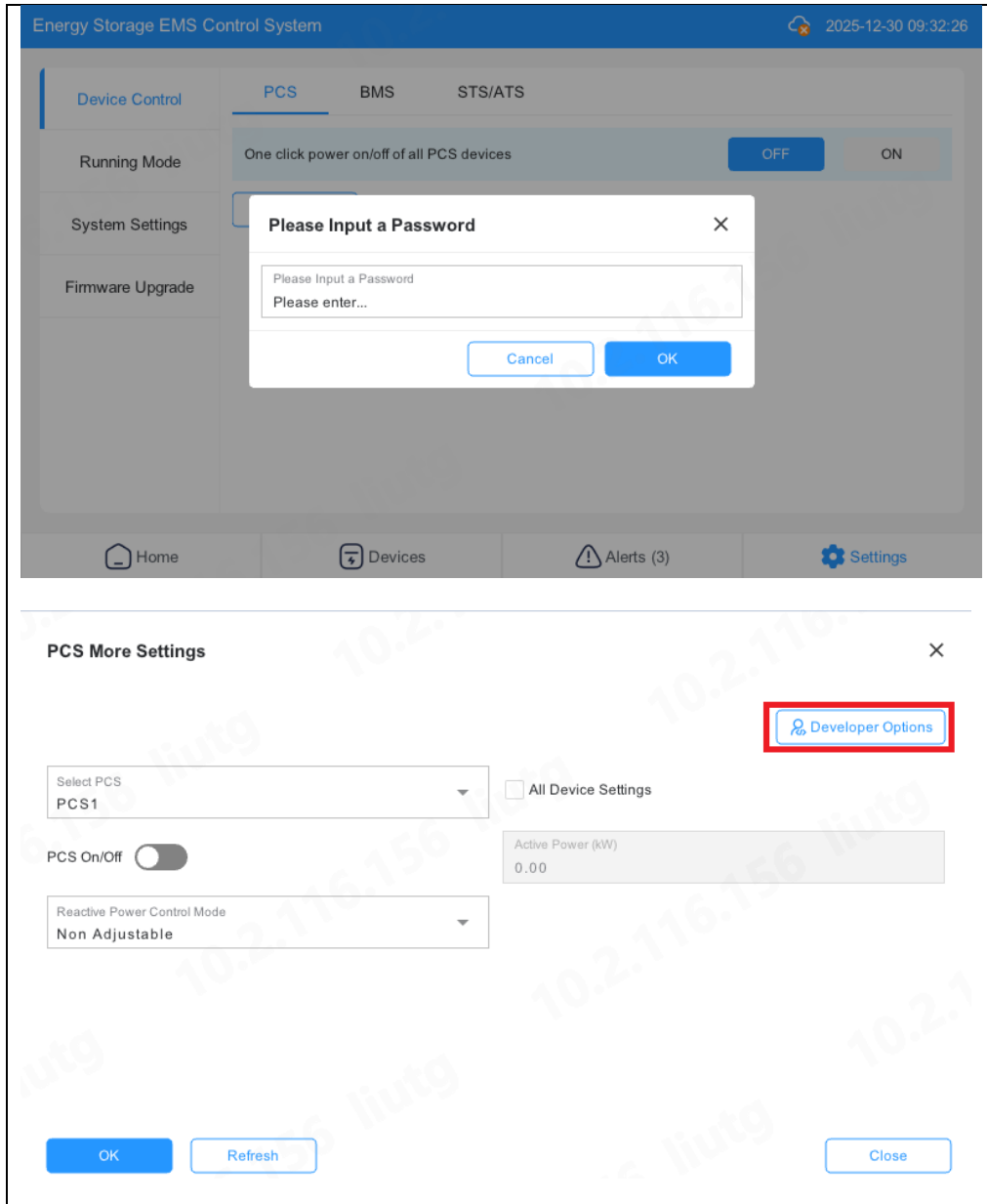

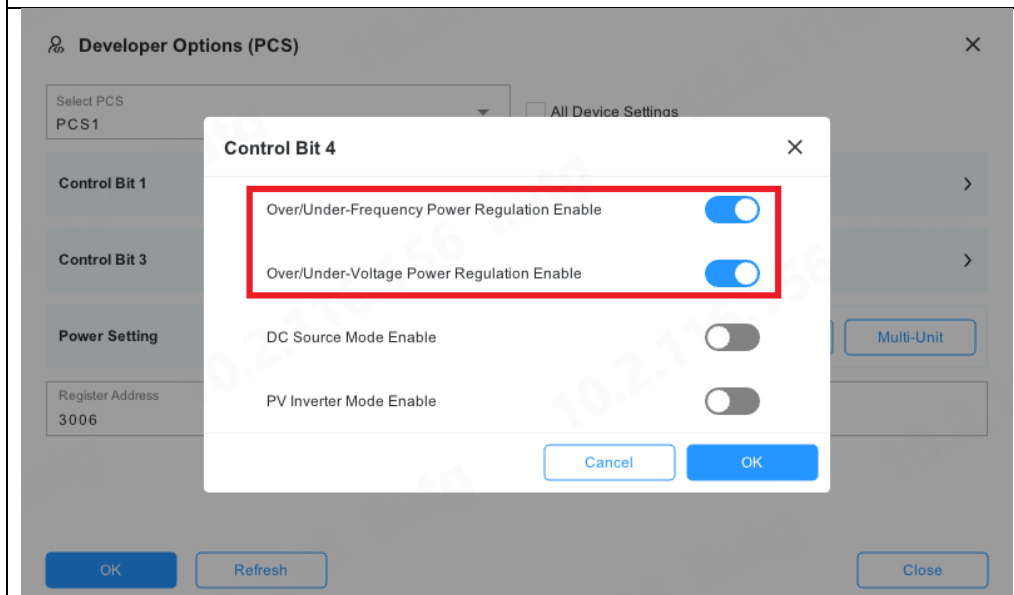
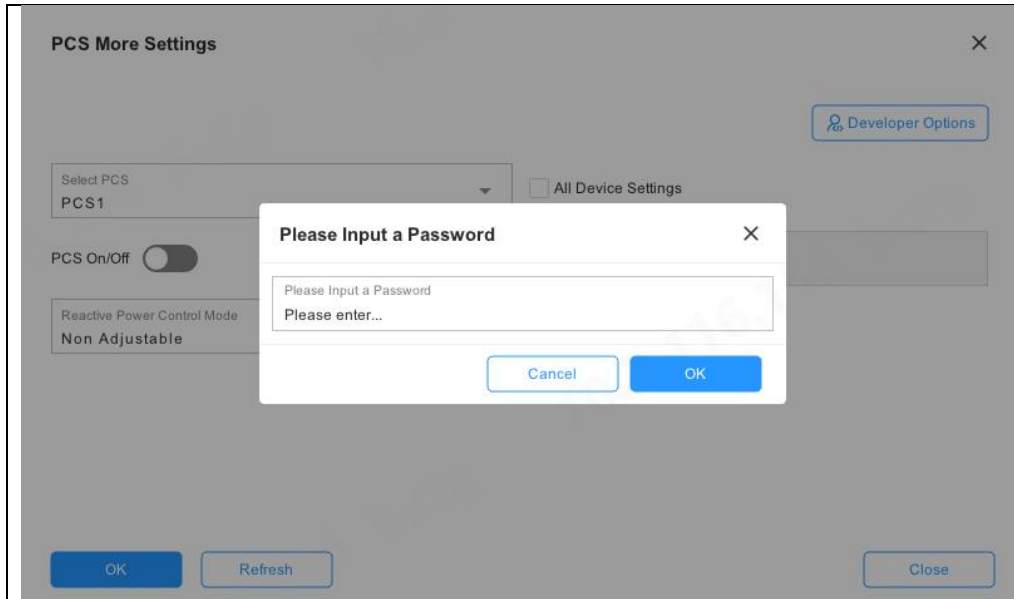

Note: The operating authority is password protected. Please contact your installer or distributor for access.

## 7.2.5 Generation limit and Export limit settings

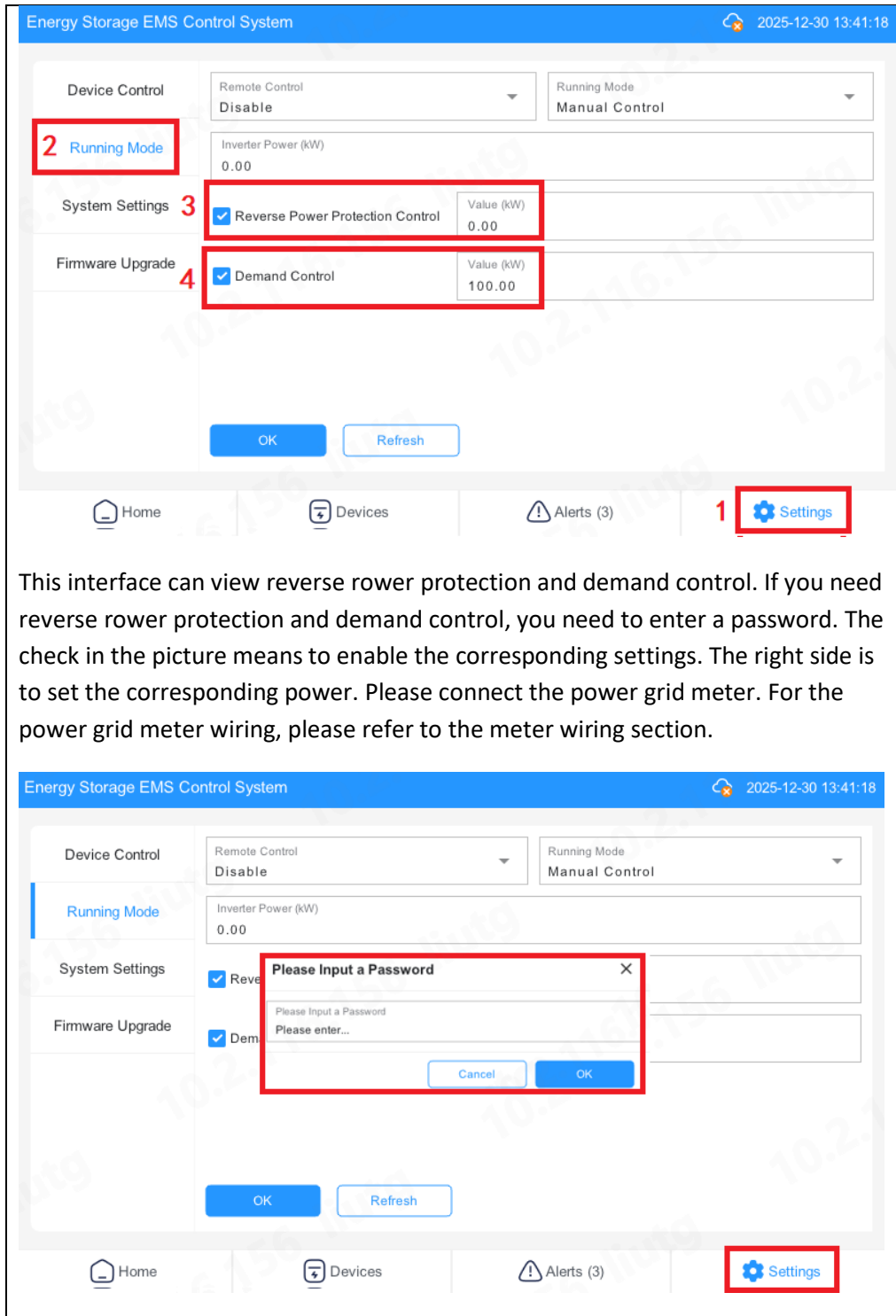

This interface can view reverse power protection and demand control. If you need reverse power protection and demand control, you need to enter a password. The check in the picture means to enable the corresponding settings. The right side is to set the corresponding power. Please connect the power grid meter. For the power grid meter wiring, please refer to the meter wiring section.

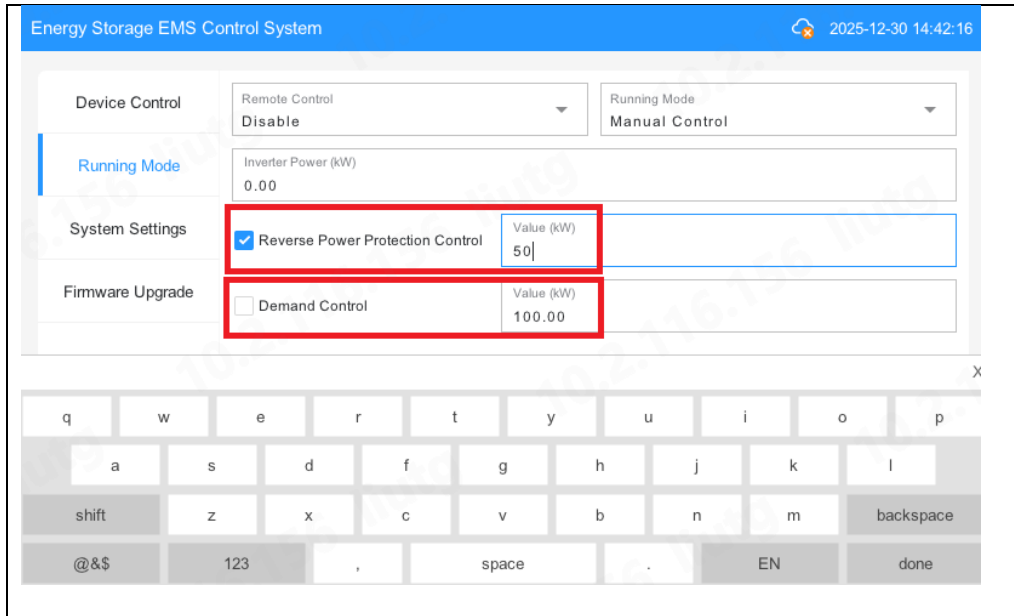

## 7.2.6 PCS total power settings

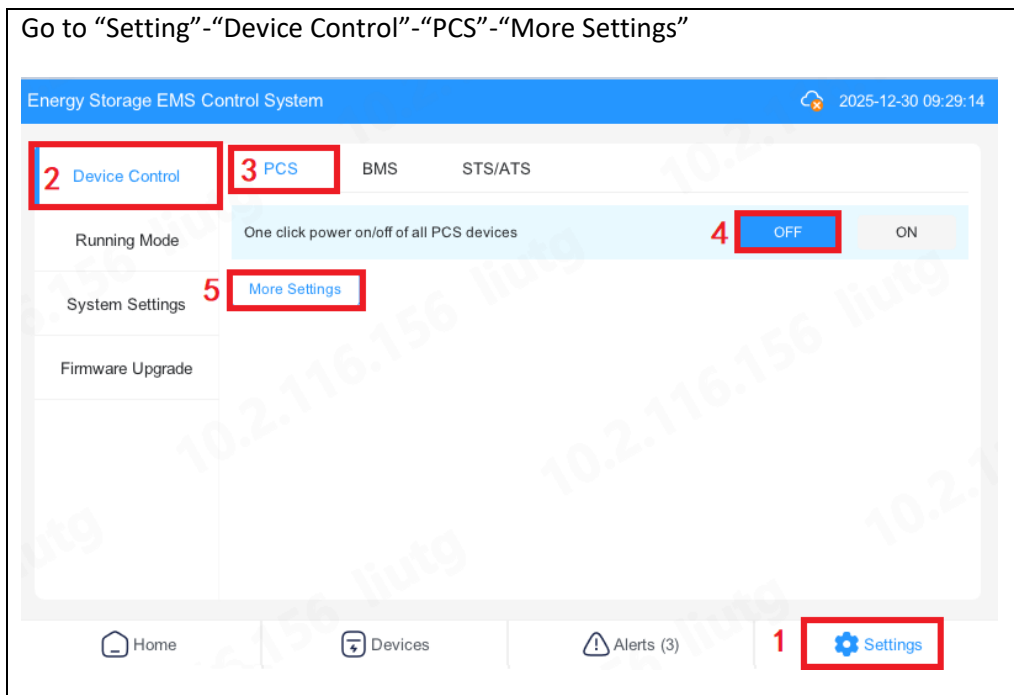

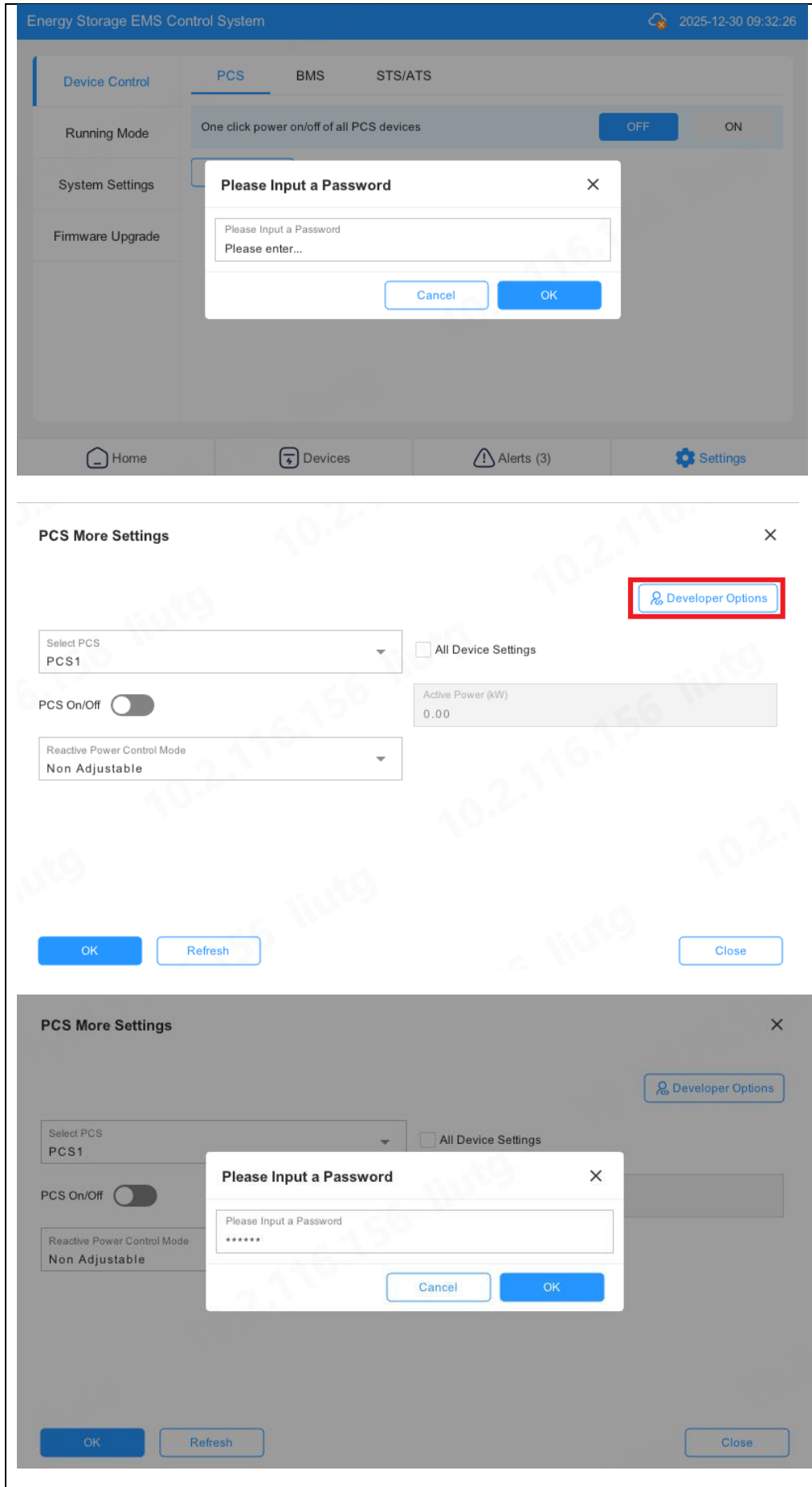

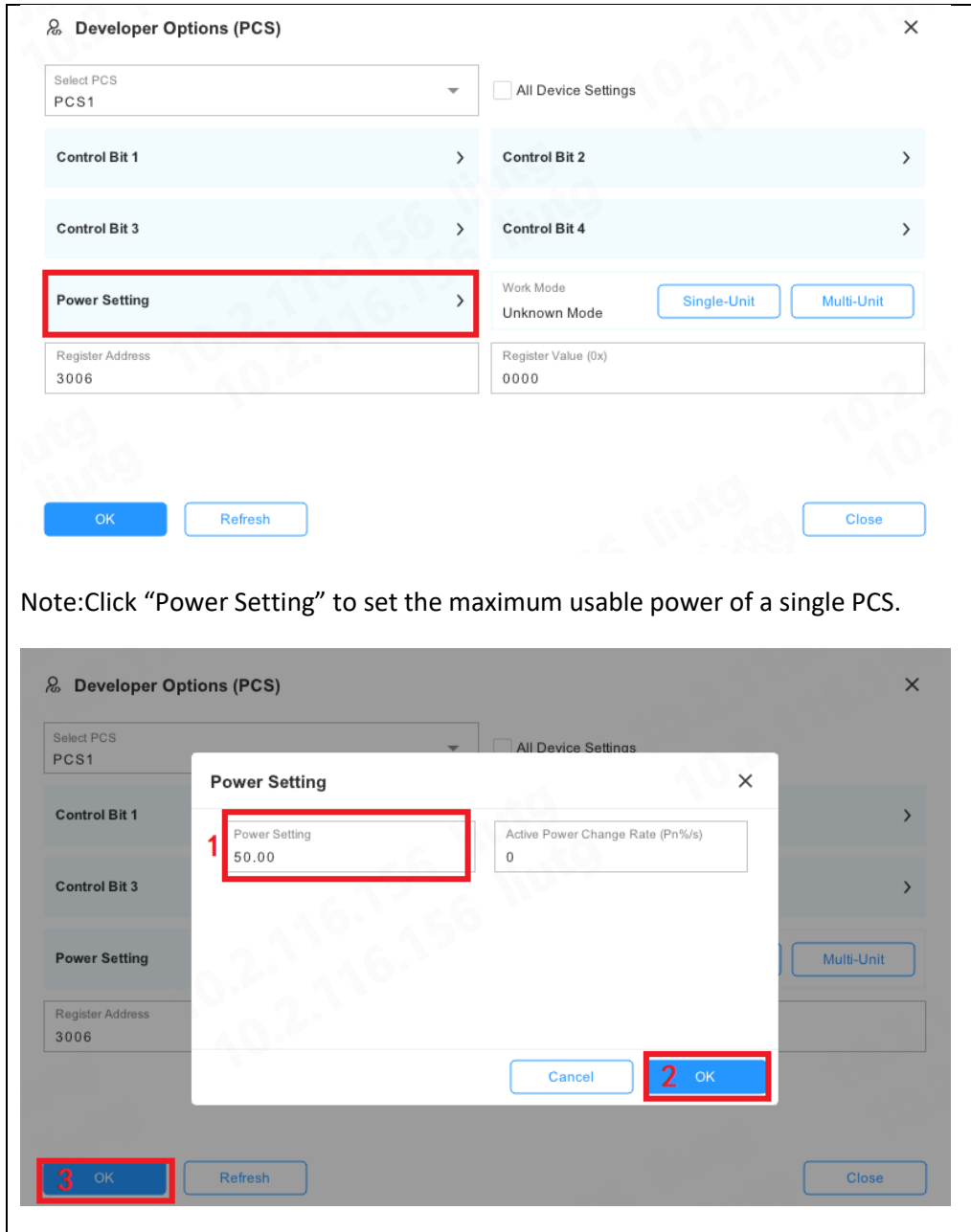

Note:Click “Power Setting” to set the maximum usable power of a single PCS.

## 7.2.7 Operation Mode Setting

### Notice:

If the ESS unit systems are connected on the EMS01D. Enable the remote control and set the run mode as “manual control”.

The set the control mode on the EMS01D.

Set the system as “manual control”, “self consumption”, “peak shaving” and “TOU” accordingly.

The image displays three screenshots of the Energy Storage EMS Control System interface, each with red boxes and numbers highlighting specific features:

- Top Screenshot (2025-07-10 21:47:52):**
  - 1:** Remote Control dropdown menu set to "Disable".
  - 2:** Run Mode dropdown menu set to "Manual Control".
  - 3:** Converter Power (kW) field set to 60.
  - 4:** Demand Control checkbox and its associated Value (kW) field set to 60.
- Middle Screenshot (2025-07-10 21:57:10):**
  - 1:** Remote Control dropdown menu set to "Disable".
  - 2:** Run Mode dropdown menu set to "Self Consumption".
  - 3:** Charging Time section, including Start Time, End Time, and Power (kW) fields.
  - 4:** Discharging Time section, including Start Time, End Time, and Power (kW) fields.
- Bottom Screenshot (2025-07-10 22:04:03):**
  - 1:** Remote Control dropdown menu set to "Disable".
  - 2:** Run Mode dropdown menu set to "Time of Use".
  - 3:** Demand Control checkbox and its associated Value (kW) field set to 60.
  - 4:** Time-Sharing Setting button.
  - 5:** OK and Refresh buttons.

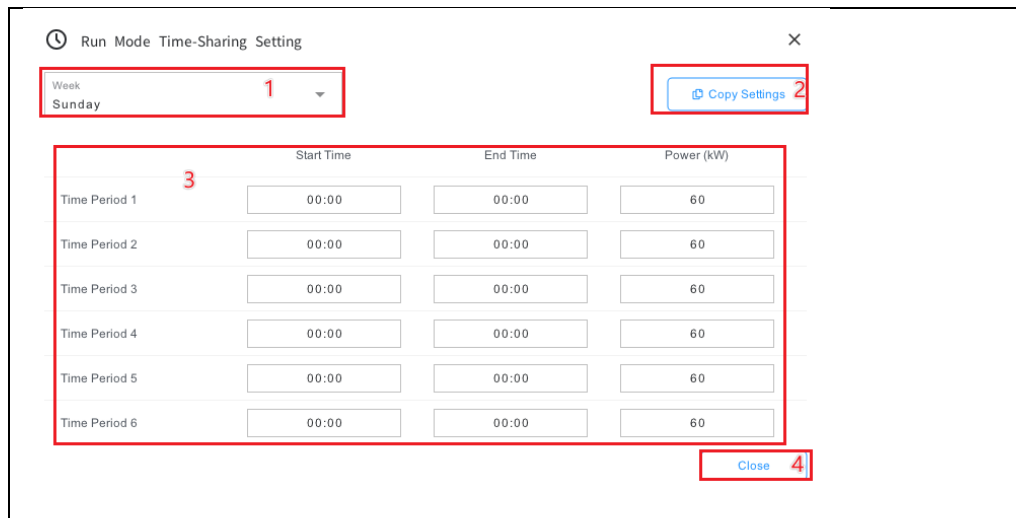

## 7.3 Startup and shutdown operation process

After the above items are met, the Power Conversion System can be started. The operation steps are as follows:

**Step 1:** Close the switches on the AC side and the DC side;

**Step 2:** Check whether the configuration information is normal through the upper computer or EMS;

**Step 3:** Issue the startup command via the upper computer or EMS;

**Step 4:** Observe that the green LED light turns on and the red LED light turns off; Otherwise, check the DTC through the upper computer or EMS.

## 7.4 Fault shutdown operation process

### 7.4.1 Shutdown Procedure

During normal maintenance or repair, the shutdown operation shall be carried out according to the following process:

**Step 1:** Issue the shutdown command through the upper computer or EMS;

**Step 2:** Disconnect the switches on the AC side and the DC side;

**Step 3:** Wait until the bus capacitor is discharged and the LED indicator turns off.

#### **Warning**

When the machine is working normally, it is strictly forbidden to directly disconnect the switch, so as to avoid the risk of arc damage to the switch.

In severe cases, it may also cause damage to the Power Conversion System.

### 7.4.2 Shutdown in case of failure or emergency

In case of emergency or failure, follow the following processes:

**Step 1:** Power off the main switch of the upstream AC grid; The main switch of the battery high-voltage cabinet is powered off.

**Step 2:** Power off the PV-SW switch on the converter.

**Step 3:** After confirming that the danger or fault has been eliminated and operation is required, close the switch.

# 8 Maintenance and Troubleshooting

## 8.1 Description

Due to the influence of ambient temperature, humidity, dust and vibration, the components inside the Power Conversion System will age, which will affect the performance of the converter and even lead to failure to work normally.

Therefore, it is necessary to carry out routine and regular maintenance of the Power Conversion System to ensure its normal operation and service life. All measures and methods that ensure the Power Conversion System remains in optimal working condition fall within the scope of maintenance.

If a fault occurs and you are unable to resolve the issue with the help of this manual, please contact Shenzhen Kstar New Energy Co., Ltd. And also, the following information shall be provided to ensure the delivery of superior service:

- Photos of the fault site
- Model and serial number of Power Conversion System.
- Information on relevant components connected to the Power Conversion System, configuration of energy storage battery and grid parameters.
- Communication connection scheme of Power Conversion System.
- Fault information and brief description.

## 8.2 Precautions

### 8.2.1 General Safety Rules

When performing maintenance, repairs, and other operations on the Power Conversion System, it is essential to adhere to the following five safety rules to ensure the safety of the operators:

- Disconnect all external power supplies to the Power Conversion System.
- Ensure that the Power Conversion System will not be accidentally re-energized.
- Use a multimeter to ensure that the inside of the Power Conversion System is completely uncharged.
- Ensure that the Power Conversion System is well grounded.
- Possible live parts adjacent to the operating part shall be insulated and covered with cloth made of insulating materials.

#### Warning

Only qualified and authorized personnel can carry out maintenance and other operations on the Power Conversion System.  
When performing maintenance work, do not leave metal parts such as screws and washers in the Power Conversion System to avoid damaging the converter!

#### Warning

If only the switch is disconnected, the cable connection terminals inside the Power Conversion System are still energized!  
Before opening the cover and starting formal maintenance, not only disconnect the switch, but also disconnect the front and rear circuit breakers of the Power Conversion System.

**Warning**

After the Power Conversion System is shut down, please wait at least 10 minutes before performing any operations on it.

**8.2.2 Maintenance Work and Cycle**

Table 8-1 List of Maintenance Items

Maintenance items	Maintenance content	Recommended cycle
Record keeping	<ul style="list-style-type: none"> <li>◆ Export the data with USB and save the backup.</li> </ul>	1 month
Inspection of converter	<ul style="list-style-type: none"> <li>◆ Observe the appearance of the Power Conversion System for damage, deformation or rust.</li> <li>◆ Listen for any abnormal sounds during the operation of the Power Conversion System.</li> <li>◆ Observe the parameters during operation through the background.</li> <li>◆ Use a thermal imager, etc. to detect system heat.</li> <li>◆ Check whether the ventilation, ambient temperature, humidity, dust and other environments around the converter meet the requirements.</li> </ul>	Half a year
Air duct cleaning	<ul style="list-style-type: none"> <li>◆ Check the air duct for dust, and clean it if it is serious.</li> <li>◆ Listen for any abnormal sounds during the operation of the fan.</li> </ul>	Half a year
Safety function	<ul style="list-style-type: none"> <li>◆ Check whether the switch fails.</li> </ul>	Half a year
Circuit connection	<ul style="list-style-type: none"> <li>◆ Check all electrical connections for looseness or poor contact.</li> <li>◆ Check all cables and metal surfaces for damage or scratches.</li> <li>◆ Check whether the insulating bandage of all terminals has fallen off</li> <li>◆ Check the screw position for signs of overheating.</li> </ul>	1 year
Identification inspection	<ul style="list-style-type: none"> <li>◆ Check the body warning signs and other equipment identifications</li> <li>◆ If it is found blurred or damaged, please replace it in time</li> </ul>	1 year

 The table only contains recommended routine maintenance cycles for the products. The actual maintenance cycle shall be determined according to the specific installation environment of the product. Factors such as the scale of the power plant, its location, and the site environment will affect the maintenance cycle of the product. If the operating environment is windy and sandy or dusty, it is necessary to shorten the maintenance period and increase the maintenance frequency.

### 8.2.3 Replacement of Components

- Replacement of components shall be carried out by professionals.
- When replacing the electrical devices in the Power Conversion System, be sure to replace the devices of the same model from the same manufacturer! The model of the device can be obtained through the Power Conversion System identification or the identification of the product itself. If you are unable to obtain the information, please contact Shenzhen Kstar New Energy Co., Ltd.
- If it is necessary to replace the product with one from another manufacturer or a different model from the same manufacturer on site, prior analysis and confirmation from Shenzhen Kstar New Energy Co., Ltd. must be obtained. Otherwise, Shenzhen Kstar New Energy Co., Ltd. assumes no responsibility for any personal injury or property damage that may result.

## 8.3 Troubleshooting

### 8.3.1 Troubleshooting

#### Warning

Under fault conditions, fatal high voltage may still exist inside the Power Conversion System! Only qualified technicians can perform the operations described in this chapter. "Qualified" refers to operators who have previously participated in professional training on various operations for equipment troubleshooting. Perform only the troubleshooting operations described in this manual. Observe all safety practices during operation.

When the Power Conversion System fails to output as expected or the charging and discharging capacity changes abnormally, please pay attention to the following items:

- Open circuit voltage of energy storage battery
- Whether the machine is in a fault state
- Whether the grid is correctly connected and energized
- Check whether the communication of the equipment is normal

### 8.3.2 Non-alarm Fault

#### **The machine is noisy when working**

Check whether the power is within the normal range; Measure whether the on-grid mode current and voltage waveform are normal; Check and replace the cooling fan.

#### **Serial communication mode:**

Check the circuit, check whether all wires are in good condition, and whether A/B is connected reversely.

The communication adapter does not match. Replace the communication adapter and try again.

Check whether the local address and baud rate are consistent with those of the upper computer.

### 8.3.3 Alarm Fault

The color of the LED indicator will display the alarm and fault items (green light: operation; yellow light: alarm; red light: fault), and the corresponding solutions are shown in Table 8-2 below:

Table 8-2 Troubleshooting Methods of Alarm Fault

Fault type	Troubleshooting method
Low battery voltage	Disconnect the DC switch and check the DC side voltage and the configuration of the energy storage battery
High battery voltage	Disconnect the DC switch and check the DC side voltage and the configuration of the energy storage battery
Battery reverse connection fault	Disconnect the DC switch and check the positive and negative wiring of the energy storage battery
Battery hardware over-current	Shut down and check whether the input and output of the converter are over-loaded or short-circuited
PV reverse connection fault	Disconnect the PV side switch and check the positive and negative wiring on the PV side
High PV voltage	Disconnect the PV side switch and check the voltage configuration on the PV side
PV hardware over-current	Shut down and check whether the input on the PV side is overloaded or short-circuited
High grid voltage	Shut down and check the voltage at the on-grid point
Low grid voltage	Shut down and check the voltage at the on-grid point
Reverse grid voltage	Disconnect the power transmission switch from the grid and shut down to check the three-phase wiring
Abnormal grid frequency	Shut down and check the grid voltage
Output relay fault	Shut down and check whether the AC relay is damaged
Converter over-current	Shut down and check whether the input and output of the converter are short-circuited or whether the converter is over-loaded
Converter wave-by-wave current limiting	Shut down and check whether the input and output of the converter are short-circuited or whether the converter is over-loaded
Converter over-temperature	Shut down and check whether the fan of the converter is malfunctioning and whether the air duct is unobstructed
Converter out-of-sync	Shut down and check the settings of the converter, and check whether the parallel cables are properly connected
Lightning protection fault	Shut down and check the lightning protection of the converter
BMS communication fault	Shut down the system and check whether the communication cable between the converter and the battery system is loose
GEN fault	Shut down the engine and check whether the wire sequence, voltage and frequency of the diesel generator port are normal
BACK-UP LOAD	Shut down the machine and check the wiring of the LOAD port

overload	or whether the load is too large
----------	----------------------------------

### 8.3.4 Protection function

The Power Conversion System has perfect protection and warning functions. When the input voltage or grid is abnormal, it can act effectively to protect the safe operation of the Power Conversion System and continue to operate in the set mode until the abnormal situation disappears.

Table 8-3 Converter Alarm and Protection Function

Function	Function description
DC over/undervoltage protection	When the DC voltage of the energy storage battery exceeds the allowable voltage range, the Power Conversion System will stop working and display the fault type on the upper computer or EMS. The Power Conversion System can quickly detect abnormal voltage and respond accordingly.
Grid over/under-voltage protection	When the Power Conversion System detects that the grid voltage exceeds the allowable voltage range, the Power Conversion System will stop working and display the fault type on the upper computer or EMS. The Power Conversion System can quickly detect abnormal voltage and respond accordingly.
Grid over/under frequency protection	When the Power Conversion System detects that the grid frequency fluctuation exceeds the allowable range, the Power Conversion System will stop working and display the fault type on the upper computer or EMS. The Power Conversion System can quickly detect abnormal frequency and respond accordingly.
Island protection	When the Power Conversion System detects that the grid voltage is 0, the Power Conversion System will stop working and display the fault type on the upper computer or EMS. The Power Conversion System can quickly detect abnormal voltage and respond accordingly.
AC over-current protection	When the output power of the energy storage battery exceeds the maximum allowable DC input power of the Power Conversion System, the Power Conversion System will limit the current and work at the maximum allowable AC output power. When the AC current is detected to be greater than 1.1 times the rated current, the Power Conversion System will stop working. After returning to normal, the Power Conversion System shall be able to work normally.
AC leakage current protection	The Power Conversion System has a grounding protection function, and the grounding cable is equipped with a leakage current sensor. When the leakage current is detected to exceed 2A, the machine will stop immediately. When the current is less than 1.5A, the protection can be eliminated. The fault is displayed through the upper computer or EMS.
IGBT over-temperature protection	The IGBT module of the Power Conversion System uses a high-precision temperature sensor, which can monitor the IGBT temperature in real time. When the temperature is too high, the DSP will issue a command to stop the Power Conversion System to protect the stable operation of the equipment

Environmental over-temperature protection	The high-precision temperature sensor is used inside the Power Conversion System, which can monitor the temperature inside the machine in real time. When the temperature is too high, the DSP will issue a command to stop the Power Conversion System to protect the stable operation of the equipment.
DC over-current protection	When the Power Conversion System detects that the DC current is greater than 1.1 times the rated current, the Power Conversion System will stop working, send an alarm signal, and display the fault type on the upper computer or EMS. After returning to normal, the Power Conversion System shall be able to work normally.
Grid phase sequence reverse protection	When the Power Conversion System detects an error in the phase of the three-phase voltage of the connected grid during self-check, the converter will send an alarm signal and display the fault type on the upper computer or EMS. After returning to normal, the Power Conversion System shall be able to work normally only after successfully completing a power-on self-test.
AC voltage unbalance protection	When the Power Conversion System detects that the difference in three-phase AC voltage exceeds the allowable range, the Power Conversion System will stop working, send an alarm signal, and display the fault type on the upper computer or EMS. The Power Conversion System can quickly detect abnormal voltage and respond accordingly.
Fan fault protection	The fan of the Power Conversion System has an automatic detection function, it can quickly send fault information to the DSP when it detects that the fan is not rotating. The DSP will issue a command to stop the operation of the Power Conversion System, while sending an alarm signal and displaying the fault type on the upper computer or EMS.
AC relay fault protection	When the operation state of the Power Conversion System is standby, on-grid mode or off-grid operation, and the AC main relay is detected to be disconnected, the Power Conversion System will stop working, send an alarm signal, and display the fault type on the upper computer or EMS.
GEN over/ under-voltage and over/under-frequency protection	When the Power Conversion System detects that the voltage and frequency fluctuation of the diesel generator exceed the allowable range, the Power Conversion System will stop working and display the fault type on the upper computer or EMS. The Power Conversion System can quickly detect abnormal voltage and frequency and respond accordingly.
BACK-UP LOAD Overload protection	When the Power Conversion System detects that the LOAD port power is too high or short-circuited, the Power Conversion System will immediately stop working and display the fault type on the screen

## Appendix I: Technical Parameters

Product Specifications	KAC20DP2	KAC25DP2	KAC29.9DP2	KAC30DP2	KAC40DP2	KAC49.9DP2	KAC50DP2
<b>PV Side</b>							
MPPT Voltage Range	250 ~ 950 Vdc (Max. 1000 Vdc)						
MPPT Rated Voltage	720 Vdc						
MPPT Rated Voltage (Full Load)	300 ~ 800 V	350 ~ 800 V	400 ~ 800 V	400 ~ 800 V	500 ~ 800 V	600 ~ 800 V	620 ~ 800 V
Max. PV Power	40 kWp	50 kWp	60 kWp	60 kWp	80 kWp	100 kWp	100 kWp
Startup Voltage	180 V						
Number of MPPT / Strings per MPPT	4 / 2						
Max. Continuous Input Current per MPPT	45 A						
Max. Short-Circuit Current per MPPT	60 A						
<b>Battery Side</b>							
Battery Type	LFP (LiFePO4)						
Battery Voltage Range	150 ~ 900 Vdc						
Battery Rated Voltage Range	180 ~ 800 Vdc						
Battery short circuit current [Adc]	120A/120A						
Max. DC Current	40 Adc x 2	50 Adc x 2	60 Adc x 2	60 Adc x 2	80 Adc x 2	80 Adc x 2	80 Adc x 2
Max. DC Power	22 kW	27.5 kW	29.9 kW	33 kW	44 kW	49.9 kW	55 kW
Number of DC Inputs	2						
<b>AC Side (On Grid)</b>							
Nominal AC Output Power	20 kW	25 kW	29.9 kW	30 kW	40 kW	49.9 kW	50 kW
Max. AC Output Power	22 kVA	27.5 kVA	29.9 kVA	33 kVA	44 kVA	49.9 kVA	55 kVA
Max. AC Input Power (Single-phase)	20 kW	25 kW	25 kW	25 kW	27.5 kW	37.5 kW	37.5 kW
Rate AC Output Current	29 A	36 A	43 A	43 A	58 A	72 A	72 A
Max. AC Input Current	64 A	80 A	87 A	96 A	128 A	144 A	160 A
AC Rated Voltage / Voltage Range	230 / 400 Vac; 220 / 380 Vac; 3L+PE+N; -15% ~ +10%						
Nominal Grid Frequency / Frequency Range	50 Hz / 60 Hz (±5 Hz)						
THDi	< 3% (100% Load)						
Adjustable PF Range	0.8 inductive(under-excited) to 0.8 capacitive(over-excited)						
<b>Backup Output</b>							
Nominal AC Voltage	230 / 400 V; 220 / 380 Vac; 3L+PE+N						
THDv	< 3% (Rated Power)						
Nominal Grid Frequency / Frequency Range	50 Hz / 60 Hz						
Nominal AC Output Power	20 kW	25 kW	29.9 kW	30 kW	40 kW	49.9 kW	50 kW
Max. AC Output Power (Single-phase)	20 kW	20 kW	20 kW	20 kW	25 kW	25 kW	25 kW
Max. Output Current	87 A	87 A	87 A	87 A	110 A	110 A	110 A
AC short circuit current [Adc]	260A						
<b>Genset Input</b>							
Max. Input Current	87 A	87 A	87 A	87 A	110 A	110 A	110 A
<b>Efficiency</b>							
Max. Efficiency	97%				97.5%		

<b>Protection</b>	
Reverse DC Connection Protection	Yes
Anti-Islanding Protection	Yes
Over-Temperature Protection	Yes
Grid Monitoring / Earthing Fault Detection	Yes
Insulation Monitoring	Yes
Overvoltage Category	DC II; AC III
Protective Class	I
Environmental Category	Outdoor
Pollution Degree	PD2 (internal), PD3 (external)
Active Anti-islanding Method	Power Variation
DC / AC Surge Protection	DC Type II; AC Type III
AFCI	Optional
<b>General Parameters</b>	
Dimensions (W x H x D)	900 x 650 x 322 mm
Weight	101 kg
Topology	Non-isolated
IP Protection	IP66
Operation Temperature Range	-25 ~ 60°C (> 45°C Derating)
Operation Humidity Range	0 ~ 100% (No Condensing)
Cooling Method	Intelligent Air Cooling
Max. Operation Altitude	3000 m (> 3000 m Derating)
Communication Port	RS-485 / CAN
Country of Manufacture	China
Warranty	10 Years

## Appendix II: Explanation of Terms

### Terms Definition

ATS automatic transfer switch  
STS static transfer switch  
AC alternating current  
DC direct current  
BESS battery energy storage system  
ESS energy storage system  
EMS energy management system  
BMS battery management system (converter)  
PCS power conversion system  
SLD Single Line Diagram  
SOH state of health (battery) in %  
SCR silicon controlled rectifier  
DOD depth of discharge, remaining battery capacity in %  
EOD end of discharge  
SOC state of charge (battery)  
UI user interface  
EPO emergency power off  
SOD Surge protection device  
BACK-UP LAOD load wiring port  
GEN generator  
DRM communication interface  
DRY dry contact  
PARA parallel port  
BAT-AC-POWER A/C wiring port  
GRID mains supply

**KSTAR**

**Shenzhen Kstar New Energy Co., Ltd.**

Address: Kstar Industrial Park, No. 7 Road, West District, High-tech Park, Guangming District, Shenzhen

Zip code: 518106

After-sales service hotline: 400-700-9662

Website: [www.kstar.com.cn](http://www.kstar.com.cn)

E-mail: [service@kstar.com.cn](mailto:service@kstar.com.cn)

※ All rights reserved. If there are any changes to the content, the latest information from our company shall prevail without prior notice.